

# 235Pro Climate Computer

## Circuit Diagrams and Cable Plans



Code no. 99-97-0301 GB

Edition: 03/2015



### Program Version

The product described in this manual contains software. This manual corresponds to:

- Software version 7.2
- It was released in 2013.

### Product and Documentation Changes

Big Dutchman reserve the right to change this manual and the product described herein without further notice. In case of doubt, please contact Big Dutchman.

**Date of change appears from the back page.**

## IMPORTANT

### NOTES CONCERNING THE ALARM SYSTEM

Where climatic control is used in livestock buildings, breakdowns, malfunctions or faulty settings may cause substantial damage and financial losses. It is therefore essential to install a separate, independent alarm system, which monitors the house concurrently with the climate computer. According to EU directive 98/58/EEC, an alarm system must be installed in any house that is mechanically ventilated.

Please note that the product liability clause of Big Dutchman.' general terms and conditions of sale and delivery specifies that an alarm system must be installed.



In case of maloperation or improper use, ventilation systems can result in production loss or cause loss of lives among animals.

Big Dutchman. recommend that ventilation systems be mounted, operated and serviced only by trained staff and that a separate emergency opening unit and an alarm system be installed as well as maintained and tested at regular intervals, according to Big Dutchman terms and conditions of sale and delivery.

### Note

- All rights belong to Big Dutchman. No part of this manual may be reproduced in any manner whatsoever without written permission from Big Dutchman.
- Big Dutchman have made reasonable efforts to ensure the accuracy of the information contained in this manual. Should any mistakes or imprecise information occur in spite of this, Big Dutchman would appreciate being notified thereof.
- Irrespective of the above, Big Dutchman shall not have any liability with respect to loss or damage caused or alleged to be caused by reliance on any information contained herein.
- Copyright 2013 by Big Dutchman.

<b>1</b>	<b>INTRODUCTION</b>	<b>7</b>
1.1	Connection of Components.....	7
<b>2</b>	<b>GENERAL INFORMATION CIRCUIT DIAGRAMS</b>	<b>8</b>
2.1	Colour Code .....	8
2.2	Example of connection .....	9
<b>3</b>	<b>OUTLINE OF CONNECTION TERMINALS</b>	<b>10</b>
3.1	Power supply (K1.1) .....	10
3.2	Main module (K1.2).....	10
3.3	I/O module (K1.3) .....	10
3.4	Triac module (K1.4) .....	10
<b>4</b>	<b>BASIC CABLE PLANS</b>	<b>11</b>
4.1	System without Emergency Opening .....	11
4.2	System with 378A ON/OFF Emergency Opening.....	11
4.3	System with 378T Temperature-controlled Emergency Opening.....	11
4.4	Winch motors.....	12
4.5	Multistep® .....	13
4.6	Dynamic MultiStep.....	13
4.7	Dynamic MultiStep, DualSpeed .....	14
4.8	Fans, Heating, Cooling, Sprinkling, 24-hour Clock, Auxiliary Sensor, and Differential Pressure Meter .....	15
<b>5</b>	<b>CIRCUIT DIAGRAMS</b>	<b>16</b>
5.1.1	Mains Voltage for I/O Module and Main Module .....	16
5.1.2	Connecting Temperature Sensors and Alarm.....	16
<b>5.2</b>	<b>Emergency Opening</b> .....	<b>17</b>
5.2.1	378 Emergency Opening ON/OFF, Medium and Large .....	17
5.2.2	378T Emergency Opening Temperature-controlled, Medium .....	17
5.2.3	378T Emergency Opening Temperature-controlled, Large .....	18
<b>5.3</b>	<b>Internal Speed Control</b> .....	<b>19</b>
5.3.1	Two Parallel Fans .....	19
5.3.2	Two Sequentially Controlled Fans .....	19
<b>5.4</b>	<b>External Speed Control</b> .....	<b>20</b>
5.4.1	MC 31.....	20

5.4.2	MC 38 External Frequency Converter .....	20
5.4.3	CL 600 LPC-motorstyring .....	21
5.4.4	CL 74CO ON/OFF to CL 600 LPC .....	22
5.4.5	CL 74CV Stepless to CL 600 LPC .....	22
<b>5.5</b>	<b>Sensors .....</b>	<b>23</b>
5.5.1	DOL 114 Temperature/Humidity Sensor and Auxiliary Sensor .....	23
5.5.2	Dynamic Air Sensor .....	23
<b>5.6</b>	<b>Winch Motors for Air Inlet .....</b>	<b>24</b>
5.6.1	CL 75A 24 V .....	24
5.6.2	CL 174 24 V .....	24
5.6.3	CL 75A 230 V .....	25
5.6.4	CL 74BC 24 V .....	25
5.6.5	CL 74CV Stepless .....	26
5.6.6	CL 175 24 V Stepless .....	26
5.6.7	CL 175 230 V Stepless .....	27
5.6.8	Two CL 74BC .....	27
5.6.9	Two CL 75A 24 V .....	27
5.6.10	Two CL 174 24 V .....	27
5.6.11	Four CL 75A 24 V .....	27
5.6.12	Four CL 174 24 V .....	27
5.6.13	CL 75A 24 V Combi-Diffuse on/off .....	28
5.6.14	CL 174 24 V Combi-Diffuse on/off .....	29
5.6.15	Combi-Diffuse Stepless .....	29
<b>5.7</b>	<b>Winch Motors for Air Outlet .....</b>	<b>30</b>
5.7.1	CL 74CV Stepless .....	30
5.7.2	Two CL 74CV Stepless .....	30
5.7.3	CL 75A 24 V .....	31
5.7.4	CL 75A 230 V .....	31
5.7.5	CL 74BC 24 V .....	32
<b>5.8</b>	<b>MultiStep® .....</b>	<b>33</b>
5.8.1	Air Outlet one-phase .....	33

5.8.2	Air Outlet three-phase.....	33
5.8.3	Gable Fan for Air Outlet.....	34
<b>5.9</b>	<b>Dynamic MultiStep, AnySpeed.....</b>	<b>35</b>
5.9.1	Air Outlet CL 74CO ON/OFF to CL 600 LPC .....	35
5.9.2	Air Outlet several fans.....	36
5.9.3	Air Outlet CL 74CV Stepless to CL 600 LPC .....	37
<b>5.10</b>	<b>Dynamic MultiStep, DualSpeed.....</b>	<b>38</b>
5.10.1	Air Outlet CL 74CO ON/OFF to CL 600 LPC .....	38
5.10.2	Air Outlet several fans.....	39
5.10.3	Air Outlet CL 74CV Stepless to CL 600 LPC .....	40
<b>5.11</b>	<b>Room/Floor Heating .....</b>	<b>41</b>
5.11.1	0-10 V Analogue.....	41
5.11.2	Relay Heating (Solenoid Valve) .....	41
5.11.3	Blowheater and stir fan .....	42
5.11.4	Relay Heating 3-phase .....	42
<b>5.12</b>	<b>Special Connections .....</b>	<b>43</b>
5.12.1	Common Exhaustion 0-10 V .....	43
5.12.2	Differential Pressure Meter .....	43
5.12.3	Cooling/Humidification/Soaking .....	44
5.12.4	Spraying/Environmental Function.....	44
5.12.5	Free Range/Catching Function.....	45
5.12.6	24-hour Clock/Water Meter.....	45
<b>5.13</b>	<b>Emergency Air Intake .....</b>	<b>46</b>
5.13.1	CL 74BC ON/OFF Winch Motor .....	46
5.13.2	CL 75A 24 V Winch Motor .....	46
5.13.3	CL 174 (24 V) Winch Motor .....	47
5.13.4	Solenoid Valve 230 V .....	47
<b>5.14</b>	<b>Connection to Equal Pressure System.....</b>	<b>48</b>
5.14.1	Equal Pressure System: MultiStep®.....	48
5.14.2	Equal Pressure System – with Inlet and Outlet on the same Speed Control.....	49

# 1 INTRODUCTION

This document contains a collection of examples of cable plans and circuit diagrams to be used for the installation of a 235Pro Climate Computer. The document may contain sections that are irrelevant to the house in question. In case of doubt, please contact Big Dutchman Service or your dealer.

## 1.1 Connection of Components



The installation, service and troubleshooting in connection with electrical equipment must be carried out by specialists in accordance with applicable national rules - in Europe in accordance with EN 60204-1 and other applicable EU rules.

The installation of a supply isolator is required for each motor and power supply, so maintenance of electrical equipment can be carried out in a dead environment. Supply isolator is not supplied by Big Dutchman.

The connection terminals in the 235Pro climate computer are universal, allowing different components to be connected to the individual terminals.

Therefore, consider the circuit diagrams in this document as examples only.

The 235Pro climate computer's installation menu (**Setup/Installation**) shows precisely the terminals to which components should be connected.

Therefore, when it says **See Show installation** in a circuit diagram, it refers to the connections that the computer gives you during the setting of the computer.

See also *Technical Manual*.



Turn to see the other connected components, and press to leave the menu.

## 2 GENERAL INFORMATION CIRCUIT DIAGRAMS

Symbols are in accordance with the IEC/EN 60617 standard.

The classification of the symbols ("letter codes") on the symbols is in accordance with the IEC/EN 81346-2 standard.

Reference designations are in accordance with IEC/EN 81346-1:2001 structuring principles and reference designations. This standard indicates structured methods for naming electrotechnical systems.

### 2.1 Colour Code

Colour code on the wires in appliance with the IEC 60757 standard: Alphabetic codes for identification of colours used on drawings, diagrams, marking, etc.:

Letter code	Color
BK	Black
BN	Brown
RD	Red
OG	Orange
YE	Yellow
GN	Green
BU	Blue (incl. light blue)
VT	Violet (purple red)
GY	Grey (slate)
WH	White
PK	Pink
GD	Gold
TQ	Turquoise
SR	Silver
GNYE	Green-and-yellow



## 2.2 Example of connection

Example: Connection of a CL 74CV winch motor to climate computer K1.

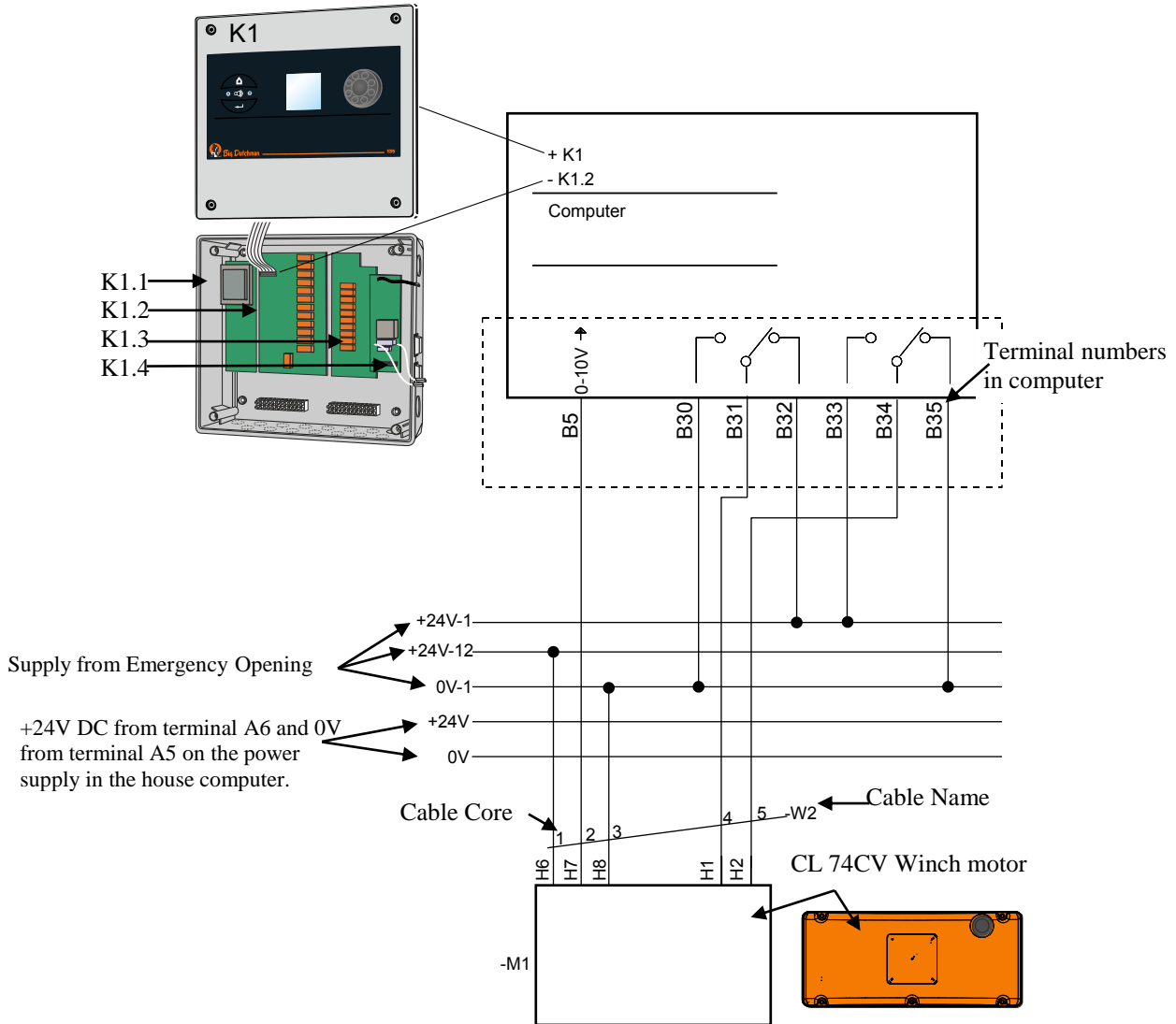

Supply from emergency opening 0V-1 = Q1 terminal in Computer.

Supply from emergency opening 24V-1 = Q2 and Q3 terminal in Computer

Supply from emergency opening 24V-2 = Q4 and Q5 terminal in Computer

Supply from emergency opening 24V-12 = F6 terminal in emergency opening.

### 3 OUTLINE OF CONNECTION TERMINALS

#### 3.1 Power supply (K1.1)

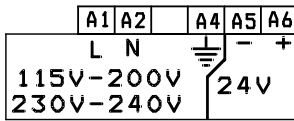

#### 3.2 Main module (K1.2)

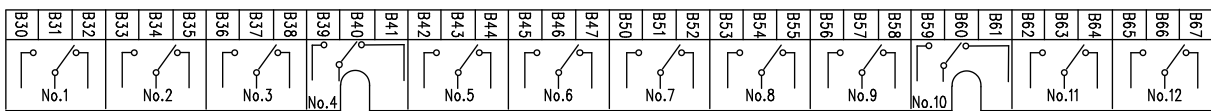
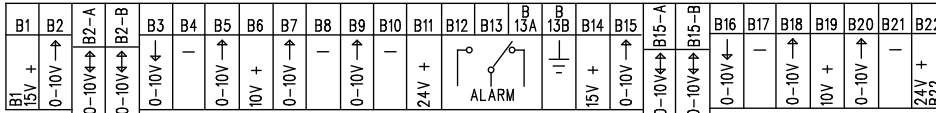

#### 3.3 I/O module (K1.3)

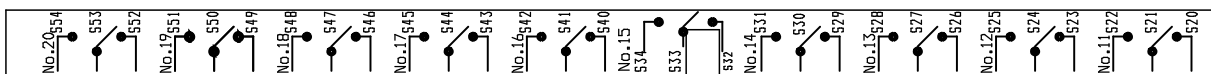
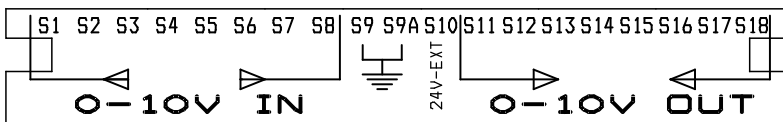

#### 3.4 Triac module (K1.4)

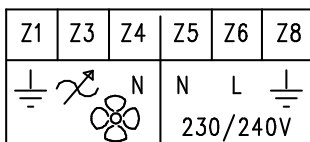

## 4 BASIC CABLE PLANS

- 1) Choose the basic cable plan of three options, which is suited for the emergency opening of the system.
- 2) Choose cables for the remaining components based on the other circuit diagrams.

### 4.1 System without Emergency Opening

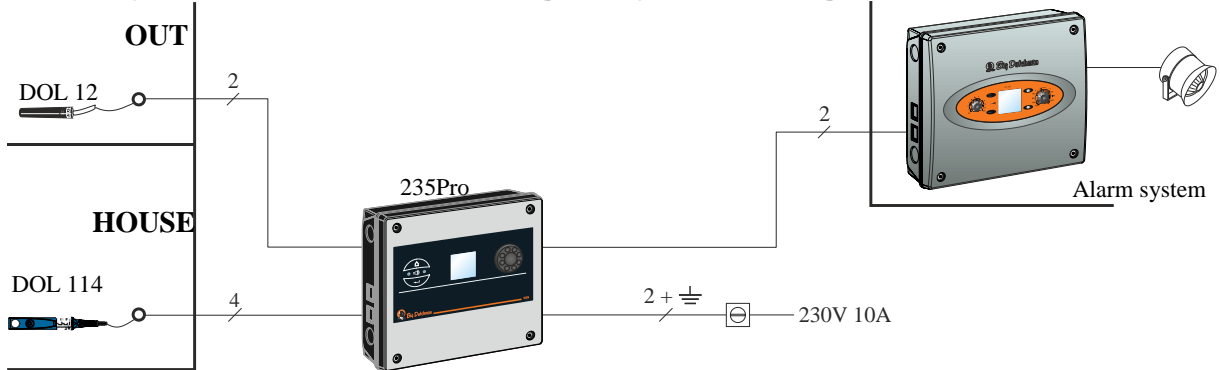

### 4.2 System with 378A ON/OFF Emergency Opening

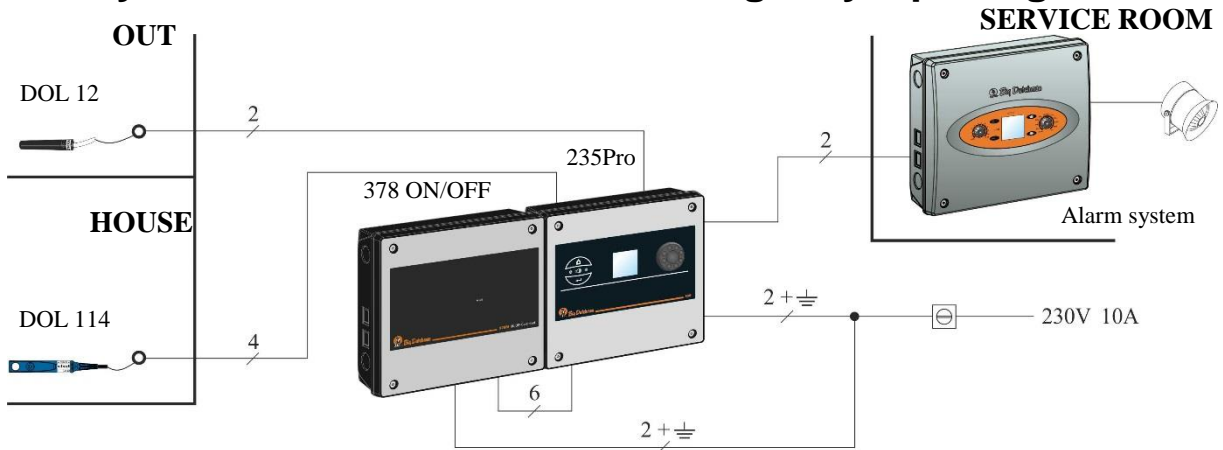

### 4.3 System with 378T Temperature-controlled Emergency Opening

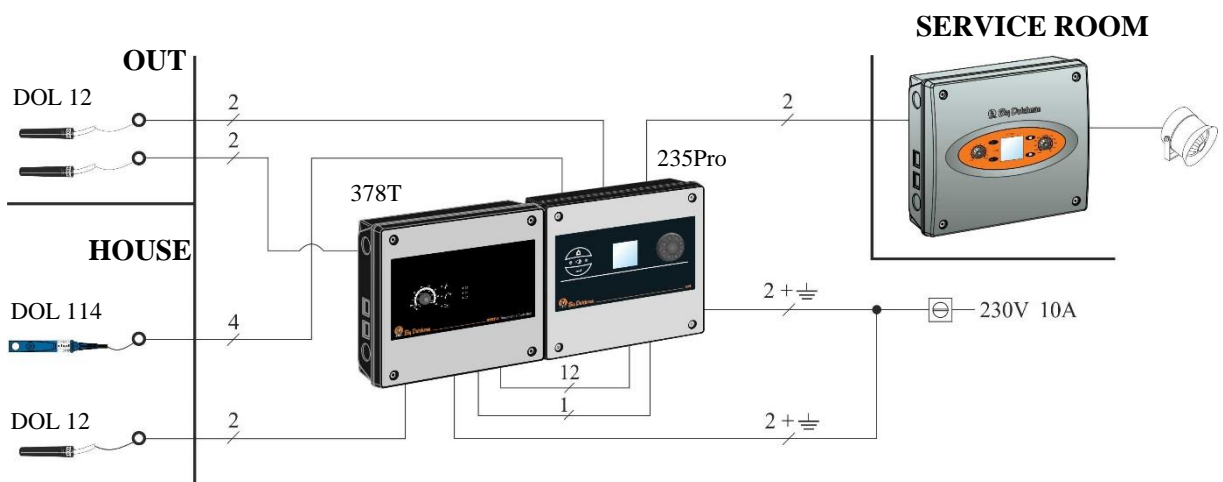

Here, 235Pro is shown as a one-house computer.

### 4.4 Winch motors

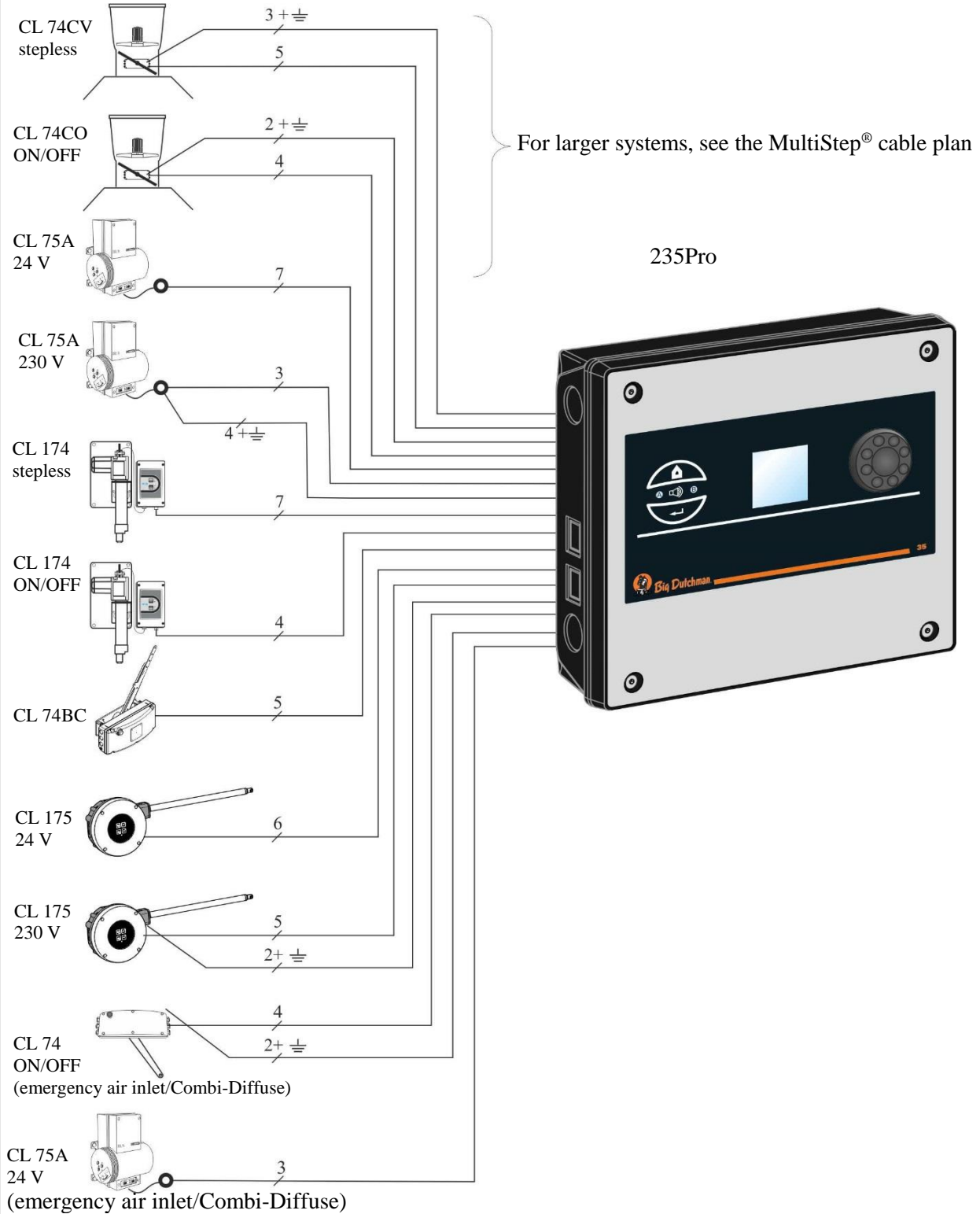

### 4.5 Multistep®

Fan supply voltage is divided among several groups, depending on the number of and the power to be supplied.

**NOTE!** Number of conductors depends on type of fan.

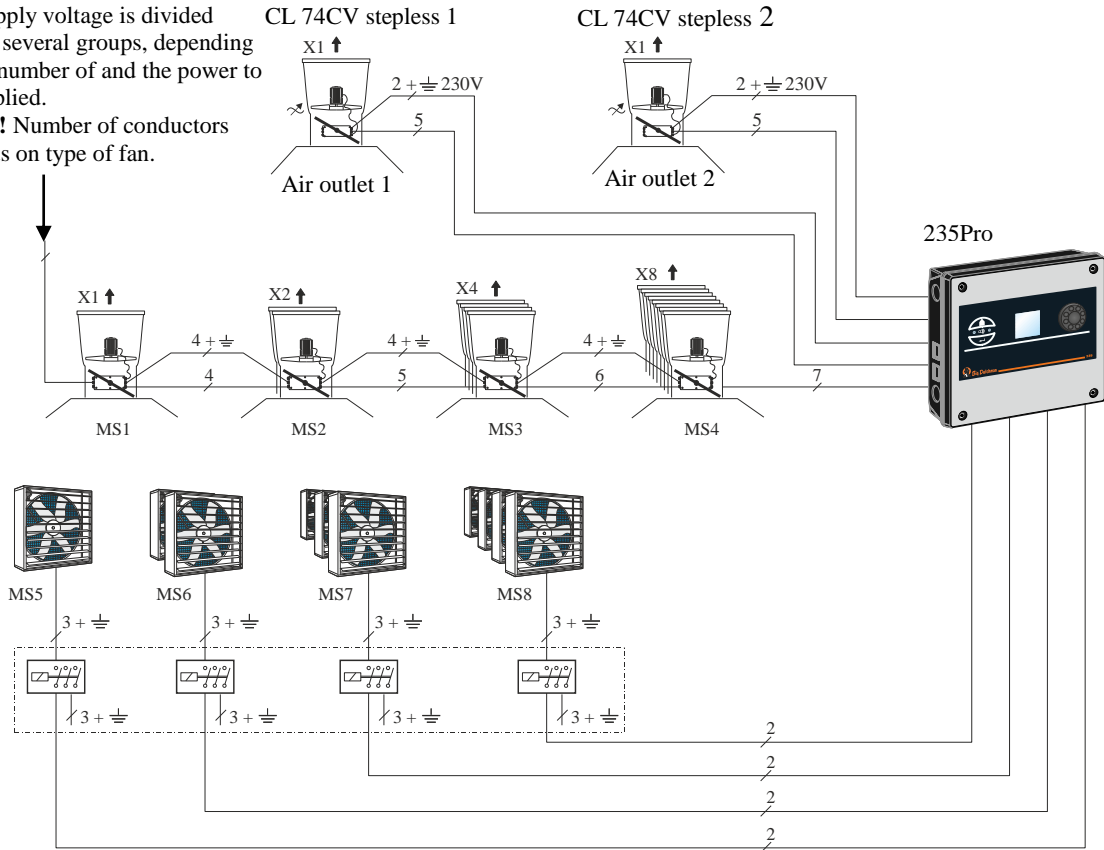

### 4.6 Dynamic MultiStep

Fan supply voltage is divided among several groups, depending on the number of and the power to be supplied.

**NOTE!** Number of conductors depends on type of fan.

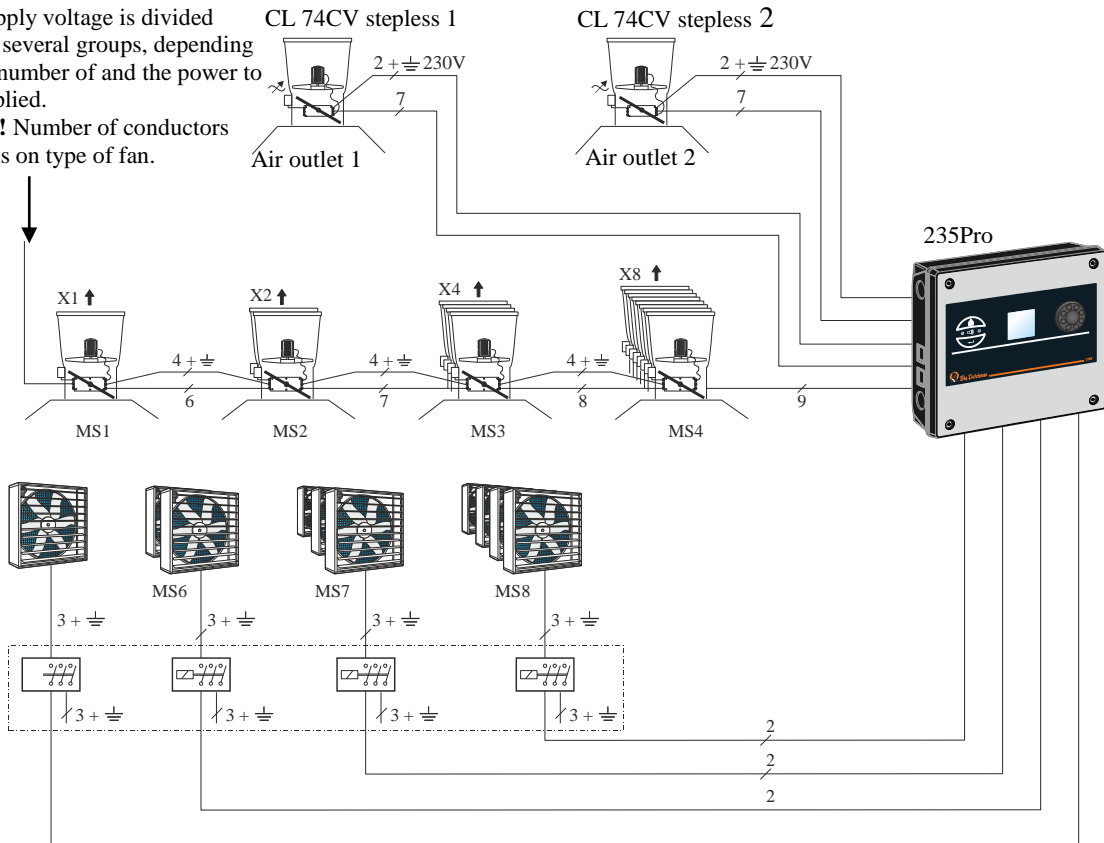

### 4.7 Dynamic MultiStep, DualSpeed

With stop relay when free range or natural ventilation is used.

Fan supply voltage is divided among several groups, depending on the number of and the power to be supplied.

**NOTE!** Number of conductors depends on type of fan.

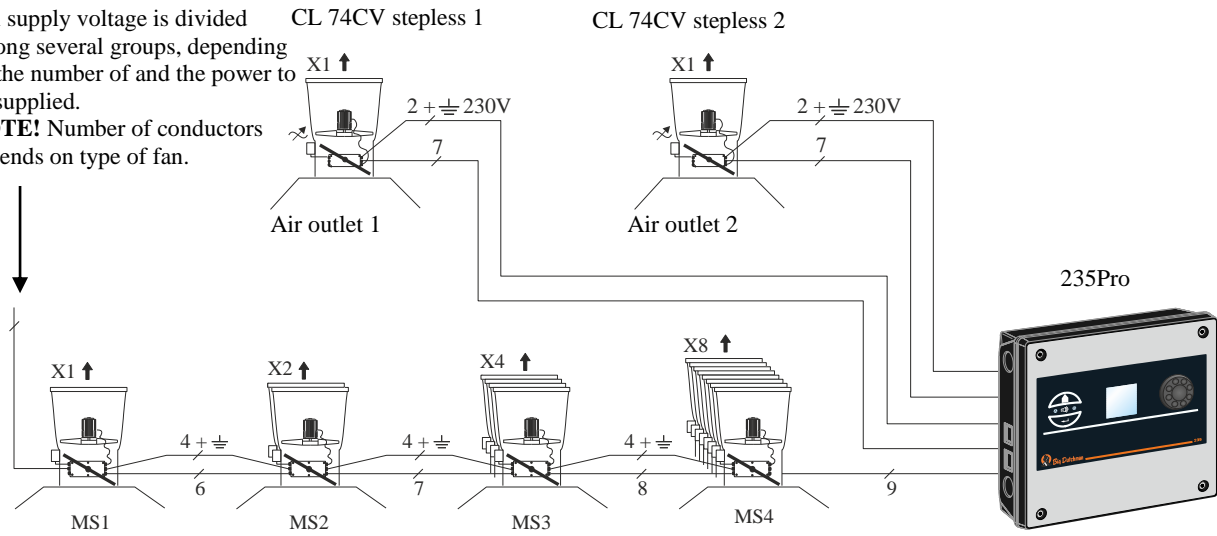

### 4.8 Fans, Heating, Cooling, Sprinkling, 24-hour Clock, Auxiliary Sensor, and Differential Pressure Meter

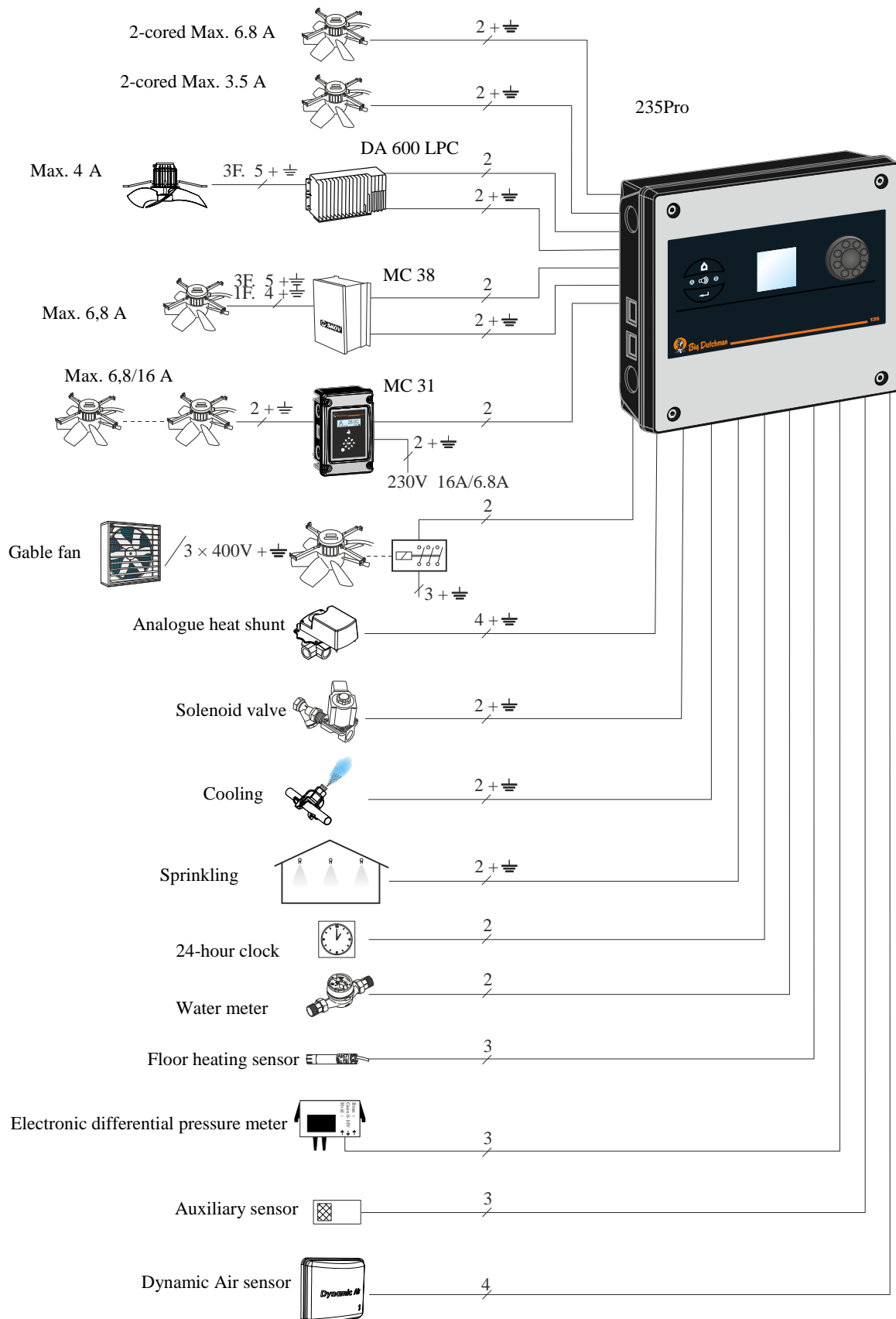

## 5 CIRCUIT DIAGRAMS

### 5.1.1 Mains Voltage for I/O Module and Main Module

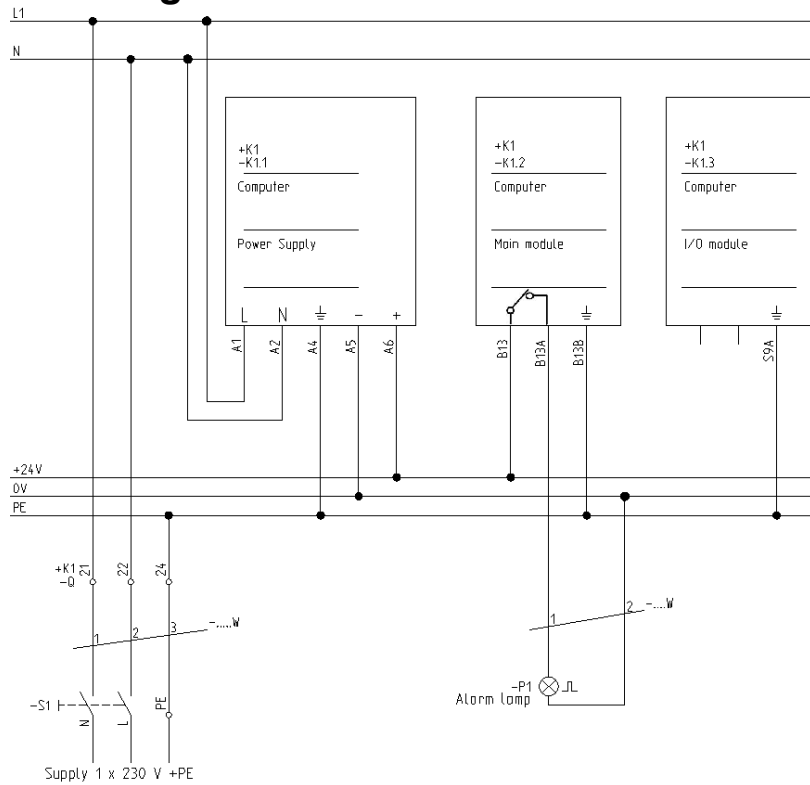

Installation in accordance with applicable national rules; supply cable, however, min. 1.5 mm<sup>2</sup>.

### 5.1.2 Connecting Temperature Sensors and Alarm



See 235Pro Technical Manual, Mounting of Climate Sensors, for correct mounting and positioning of climate sensors.

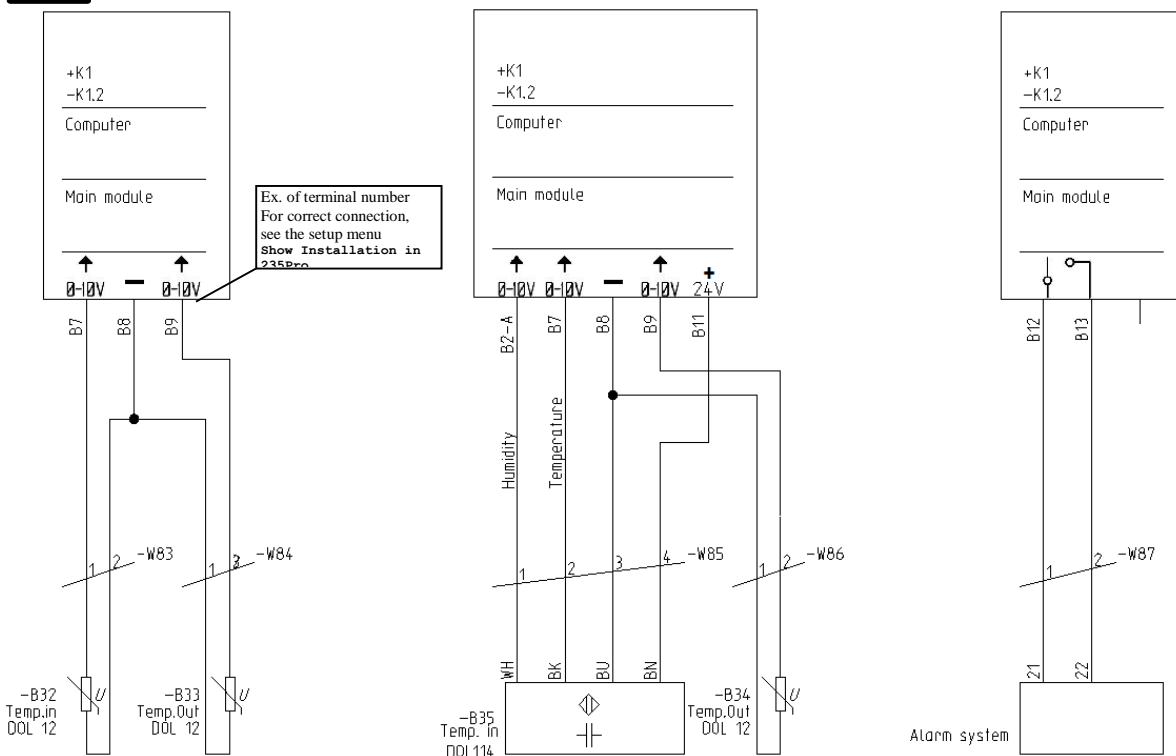



## 5.2 Emergency Opening

### 5.2.1 378 Emergency Opening ON/OFF, Medium and Large

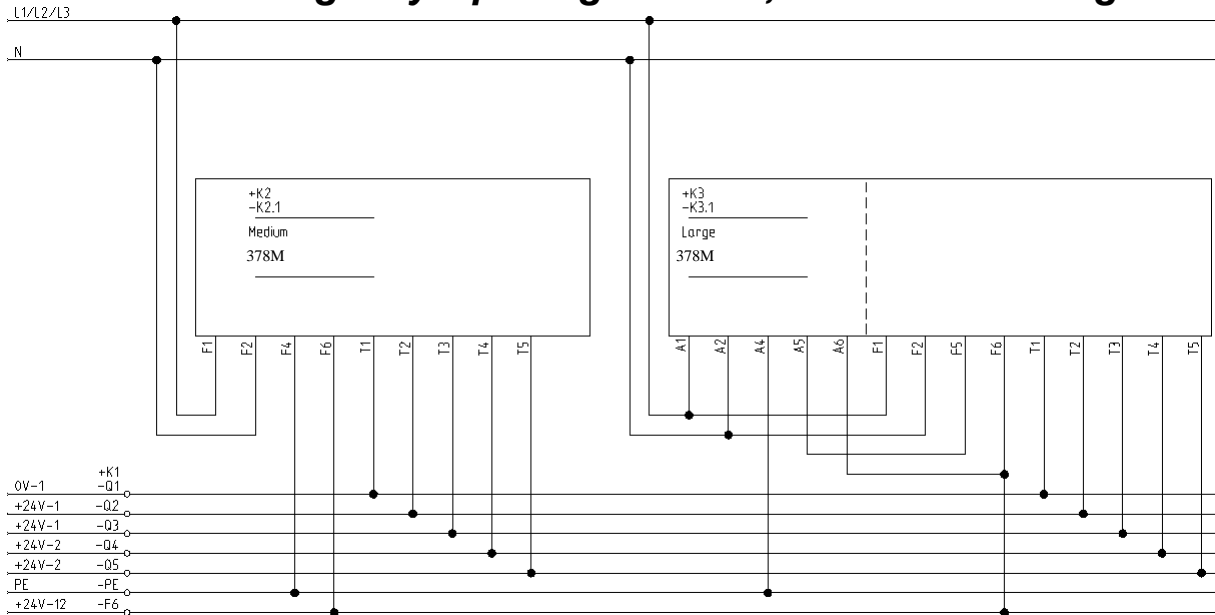

### 5.2.2 378T Emergency Opening Temperature-controlled, Medium

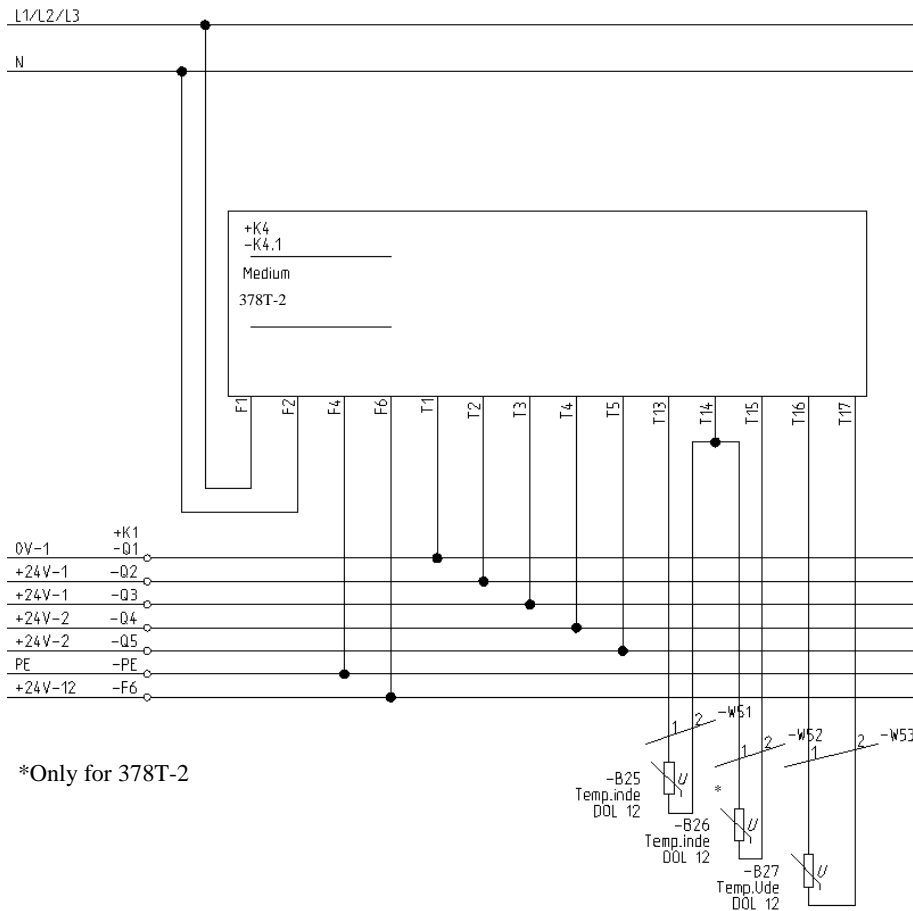

### 5.2.3 378T Emergency Opening Temperature-controlled, Large

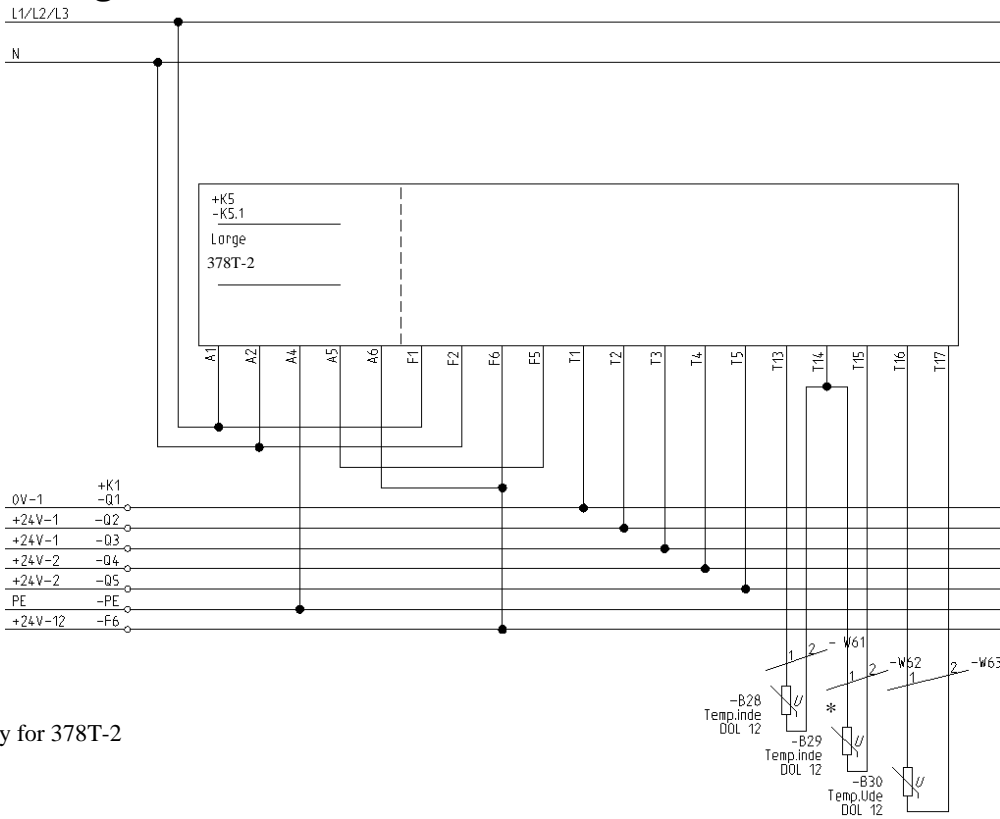

\*Only for 378T-2

### 5.3 Internal Speed Control

#### 5.3.1 Two Parallel Fans

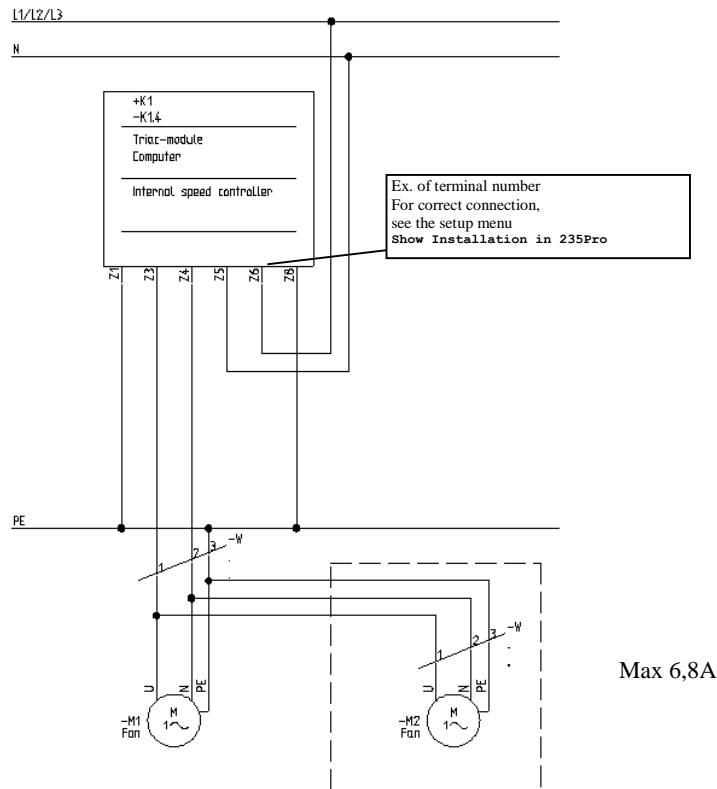

#### 5.3.2 Two Sequentially Controlled Fans

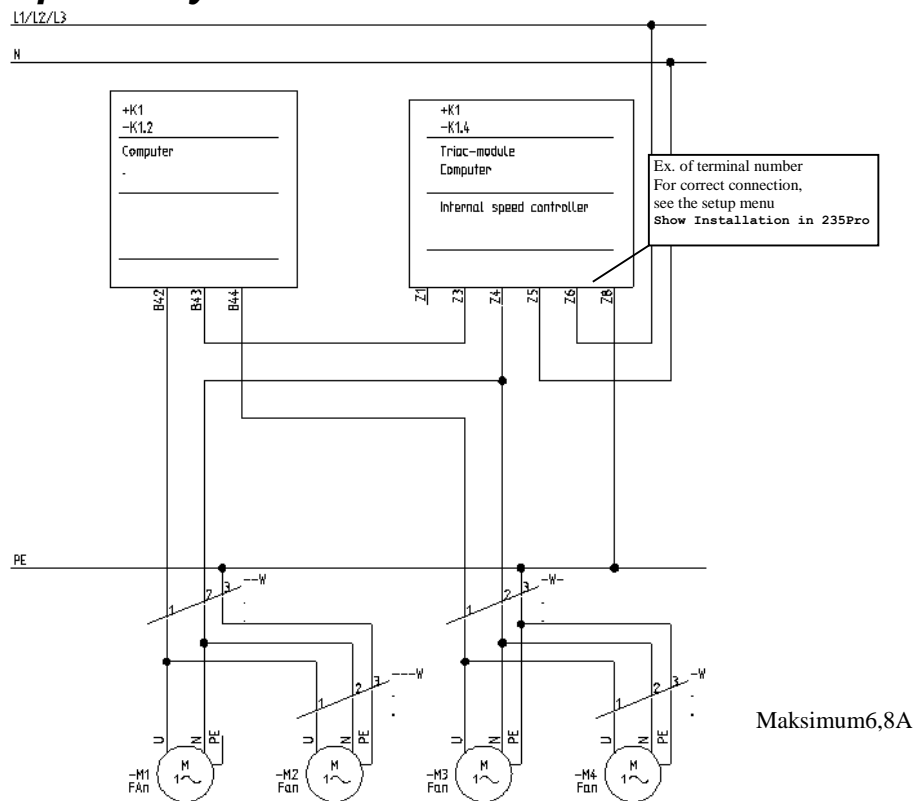

## 5.4 External Speed Control

### 5.4.1 MC 31

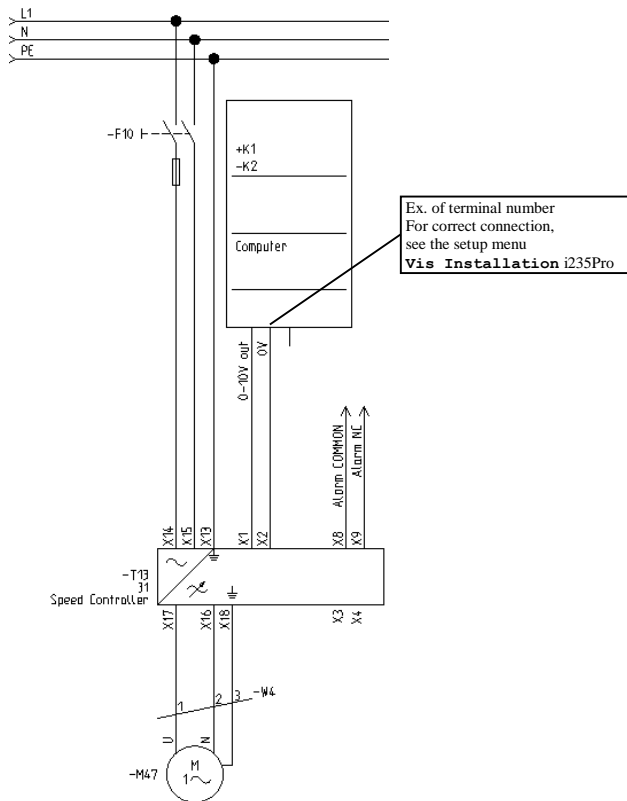

### 5.4.2 MC 38 External Frequency Converter

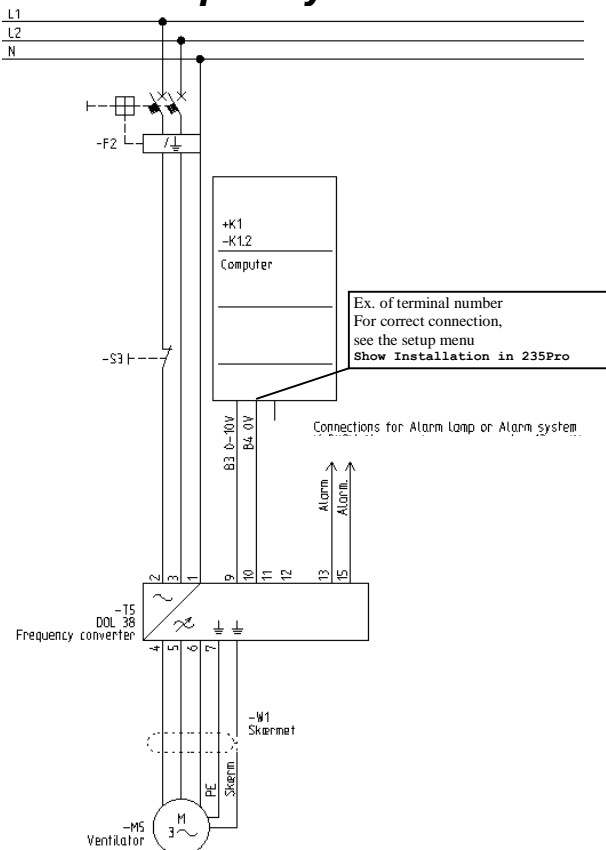

### 5.4.3 CL 600 LPC-motorstyring

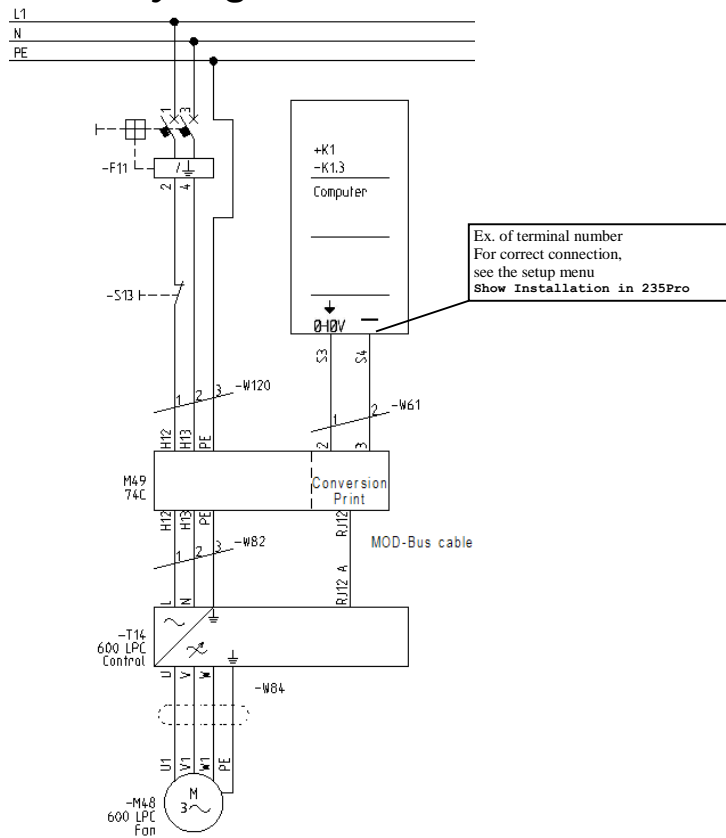

### 5.4.4 CL 74CO ON/OFF to CL 600 LPC

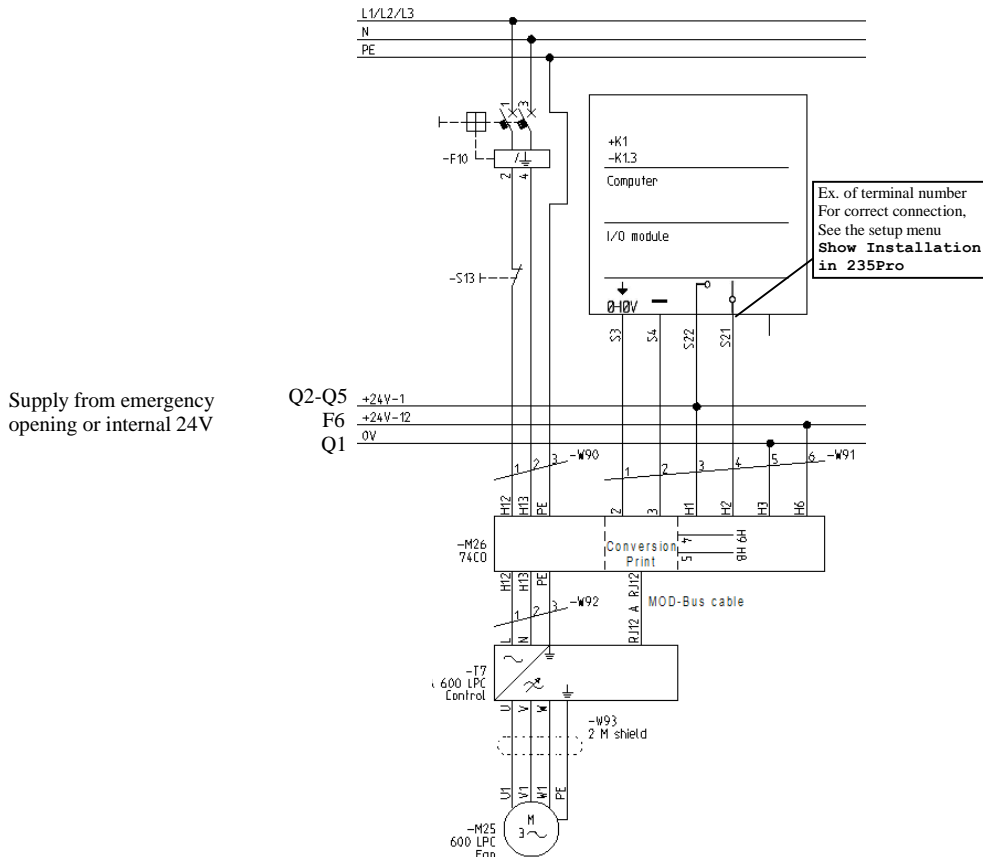

### 5.4.5 CL 74CV Stepless to CL 600 LPC

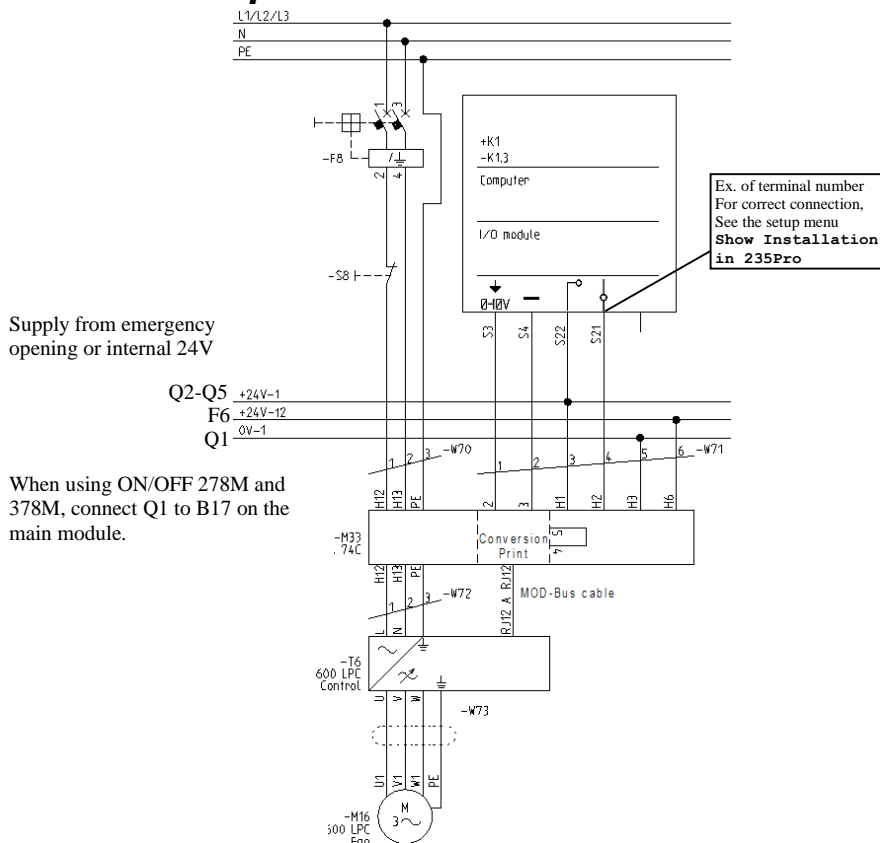

## 5.5 Sensors



See *235Pro Technical Manual, Mounting of Climate Sensors*, for correct mounting and positioning of climate sensors

### 5.5.1 DOL 114 Temperature/Humidity Sensor and Auxiliary Sensor

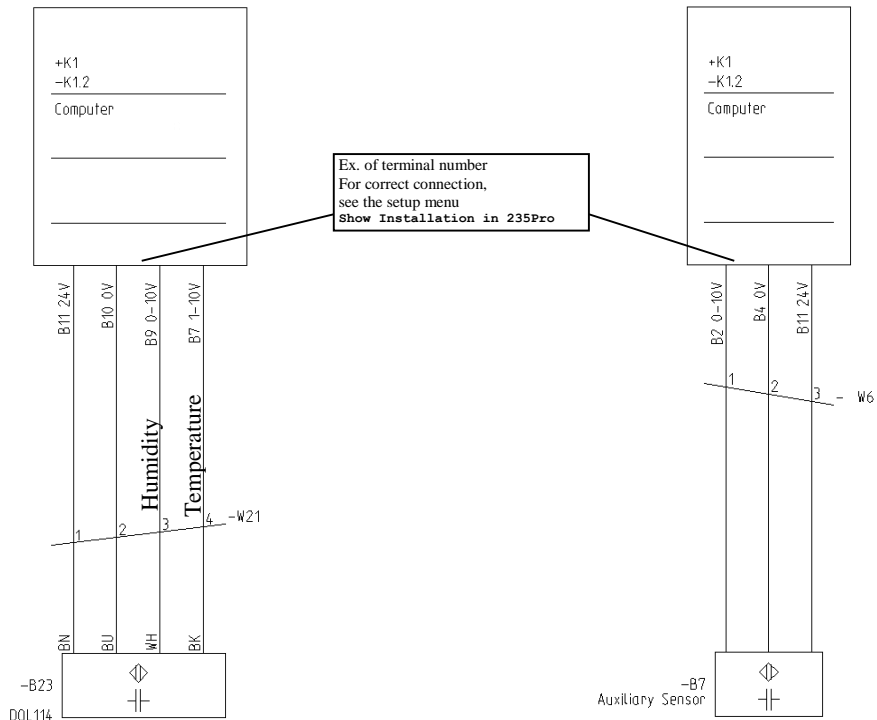

### 5.5.2 Dynamic Air Sensor

Run the blue and black wire separately to the climate computer where the wires should be connected in a negative terminal.

Do not connect the wires to other earth wires on the way to the

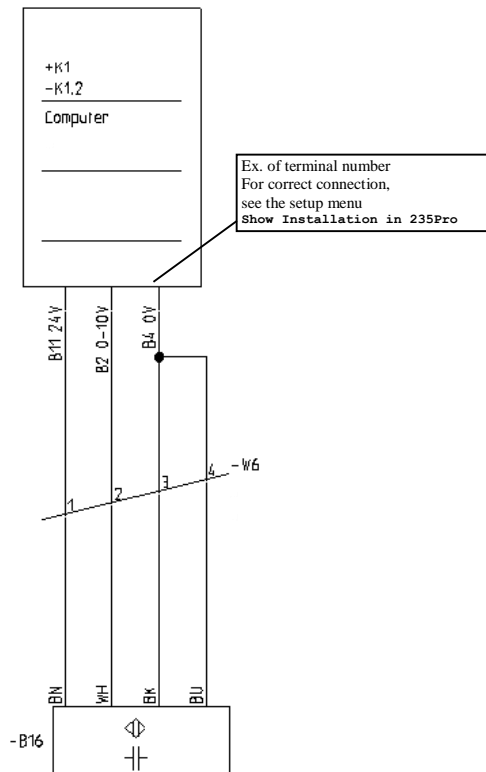

## 5.6 Winch Motors for Air Inlet

### 5.6.1 CL 75A 24 V

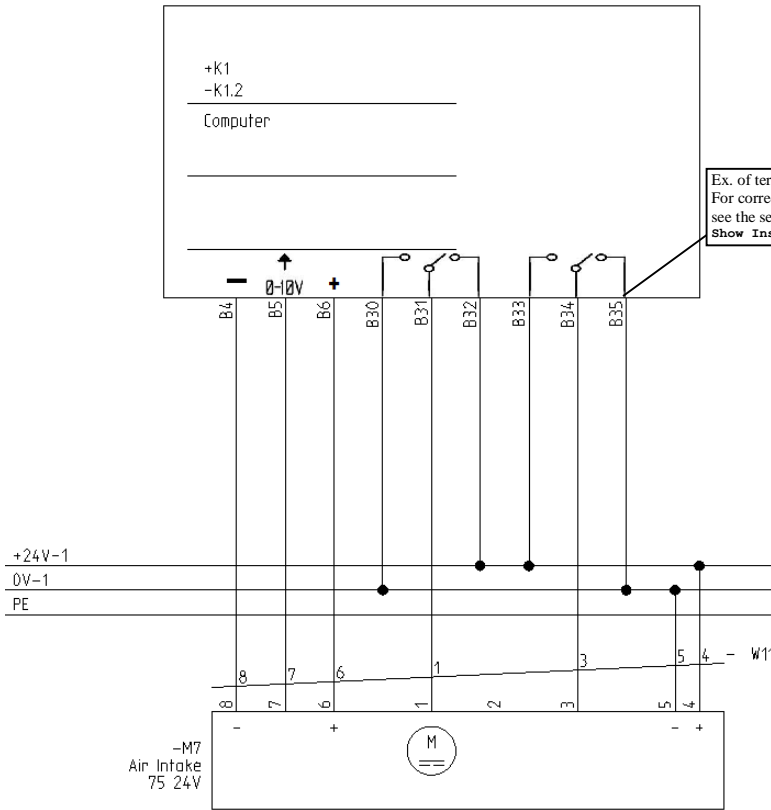

Cable dimensions for 24V DC motors depending on length	
24 V DC	
Length < 70 m	7 x min. 1,0 mm <sup>2</sup>
70 < Length < 100 m	7 x min. 1,5 mm <sup>2</sup>
100 < Length < 165 m	7 x min. 2,5 mm <sup>2</sup>
165 < Length < 265 m	7 x min. 4,0 mm <sup>2</sup>

### 5.6.2 CL 174 24 V

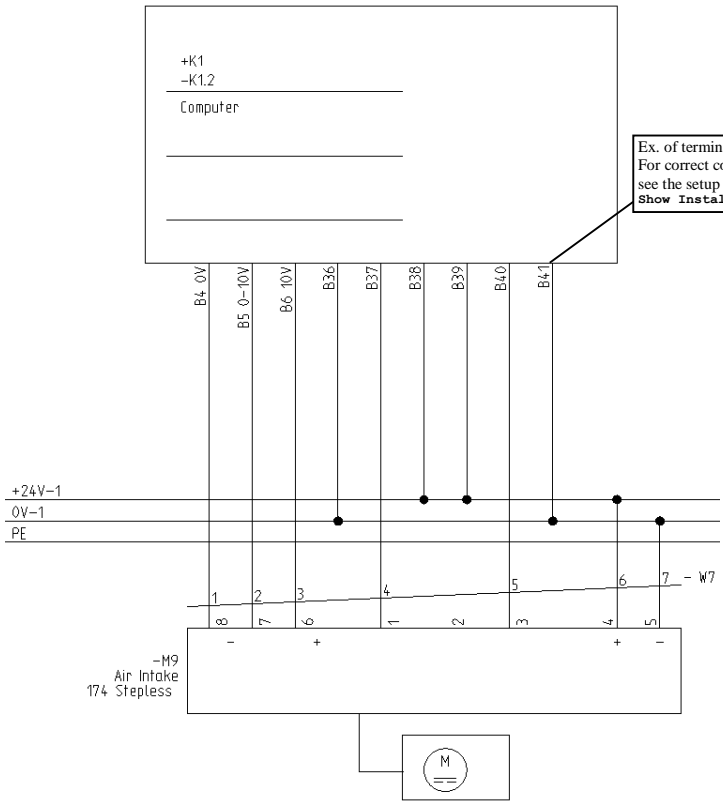

Cable dimensions for 24V DC motors depending on length	
24 V DC	
Length < 70 m	7 x min. 1,0 mm <sup>2</sup>
70 < Length < 100 m	7 x min. 1,5 mm <sup>2</sup>
100 < Length < 165 m	7 x min. 2,5 mm <sup>2</sup>
165 < Length < 265 m	7 x min. 4,0 mm <sup>2</sup>



### 5.6.3 CL 75A 230 V

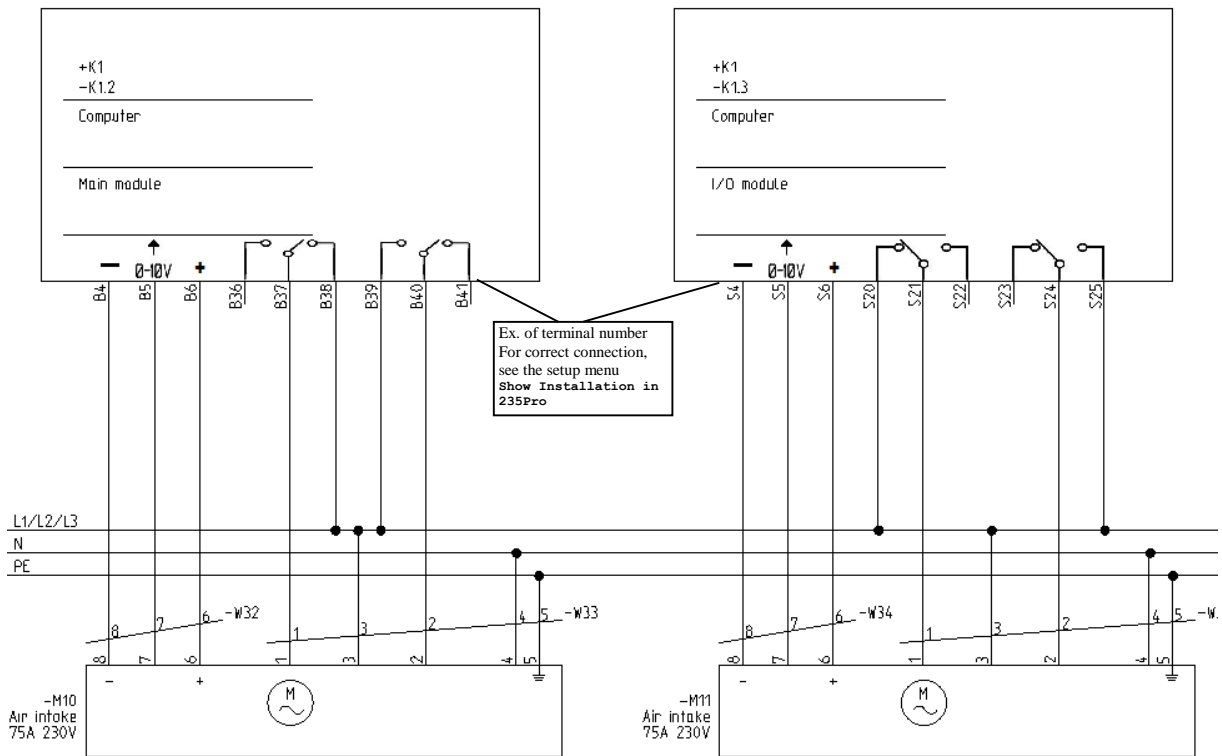

Installation in accordance with applicable national rules. However, cable dimension min. 1.5 mm<sup>2</sup>.

### 5.6.4 CL 74BC 24 V

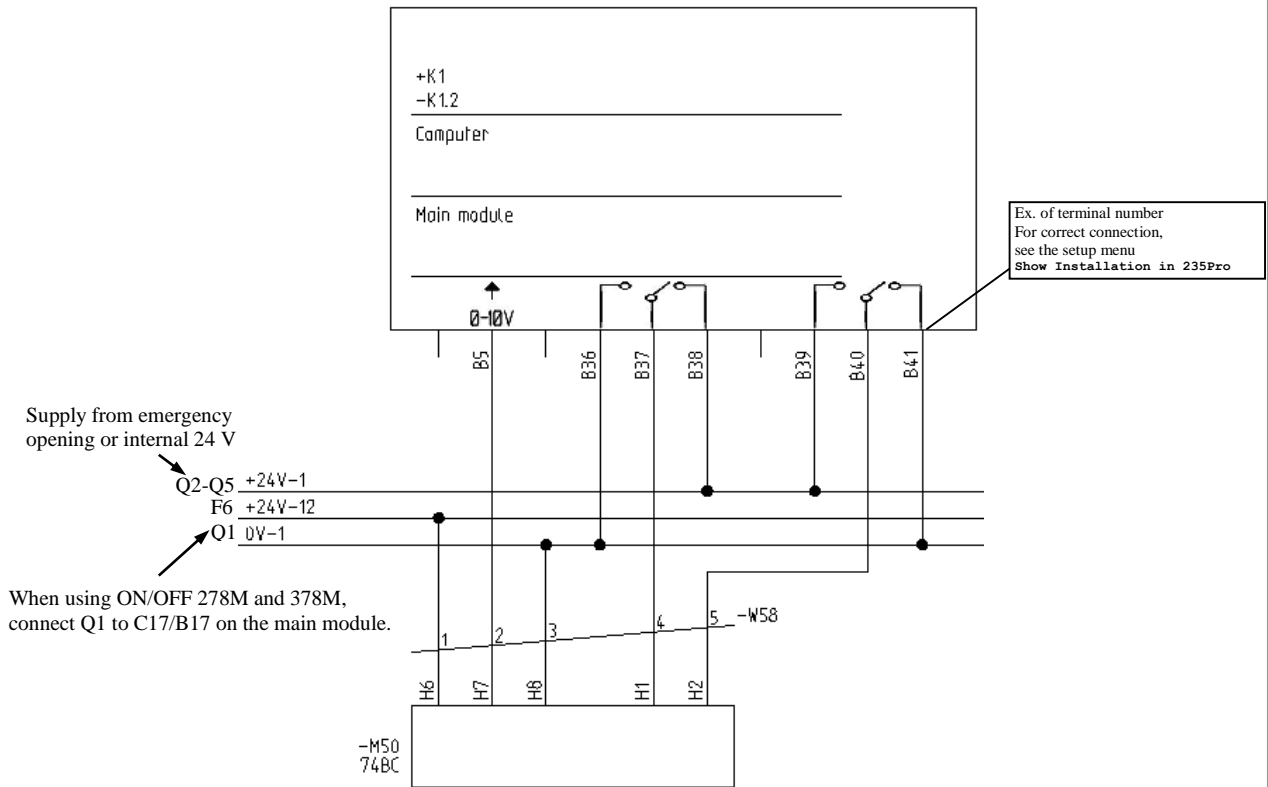

### 5.6.5 CL 74CV Stepless

NOTE: In house 2, move L1 to L2

(the fixed phase must be the same for the winch motor and speed control).

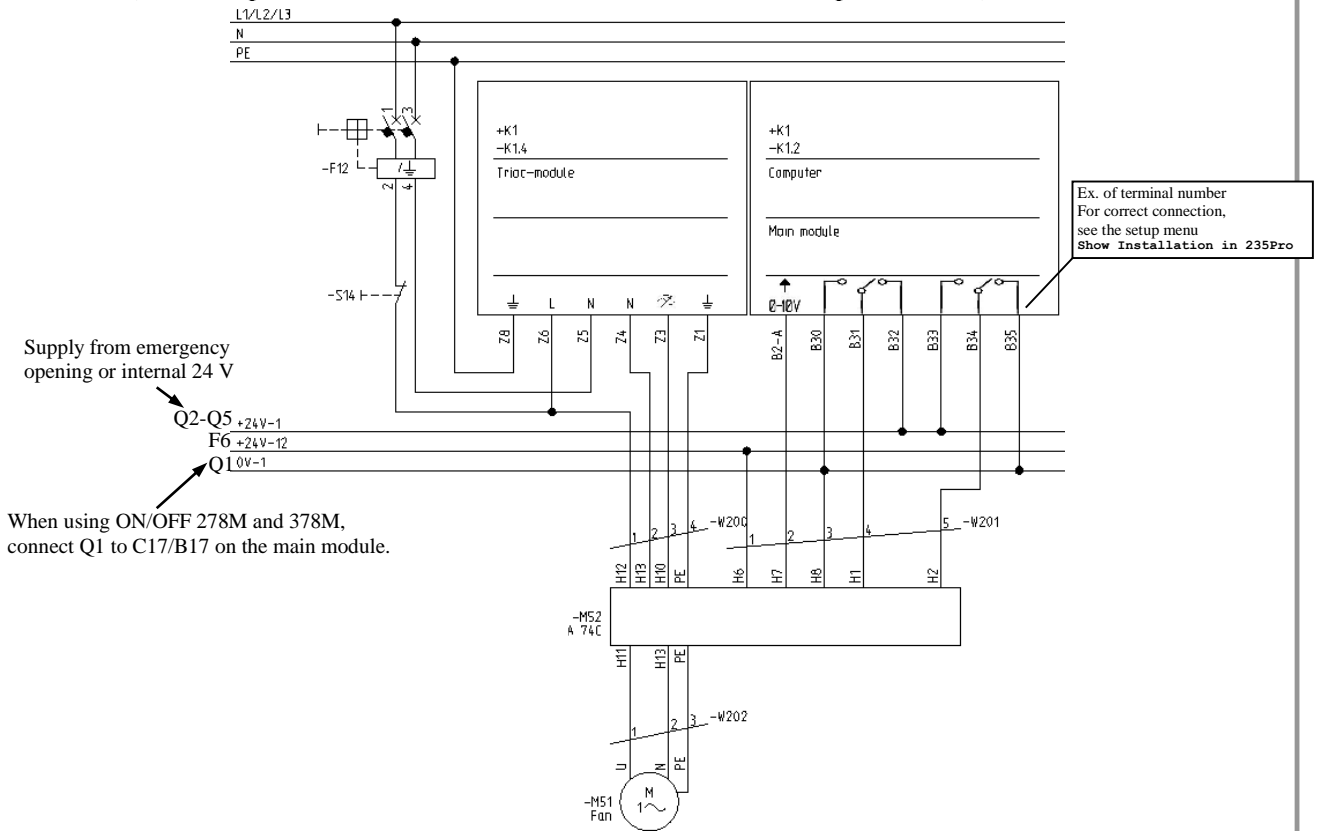

### 5.6.6 CL 175 24 V Stepless

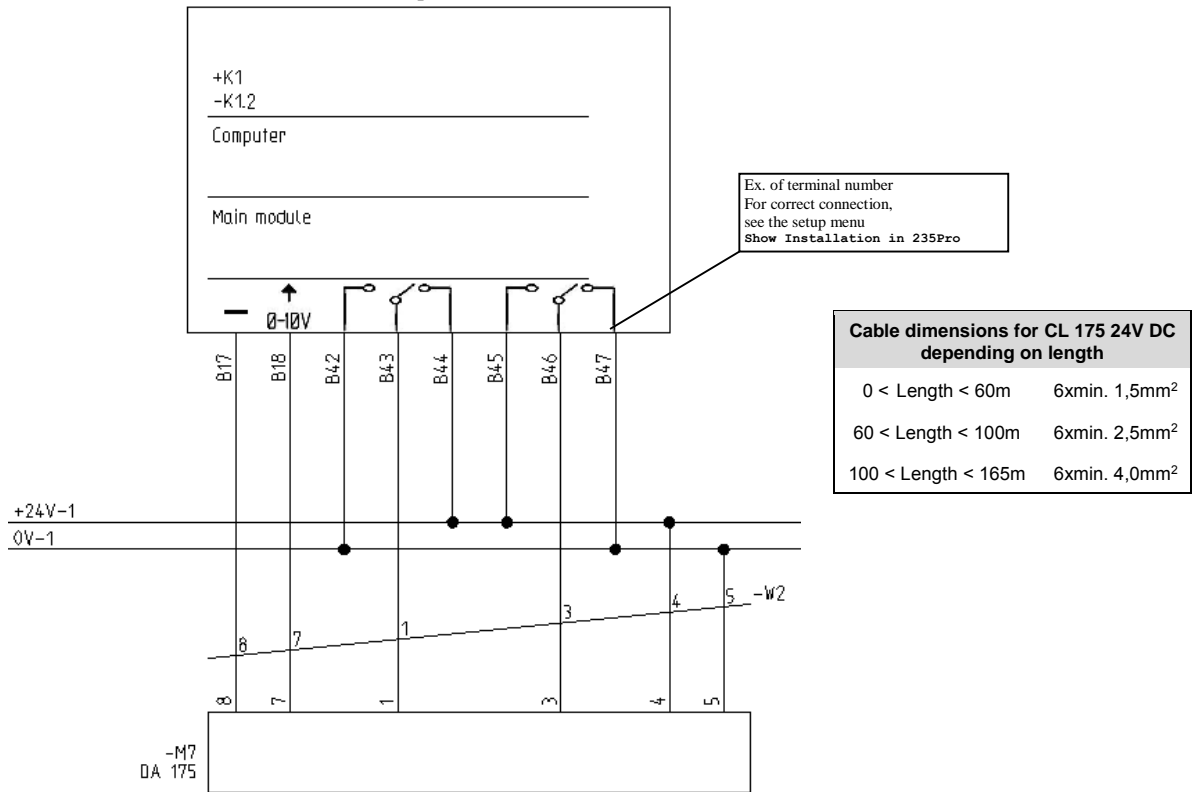

### 5.6.7 CL 175 230 V Stepless

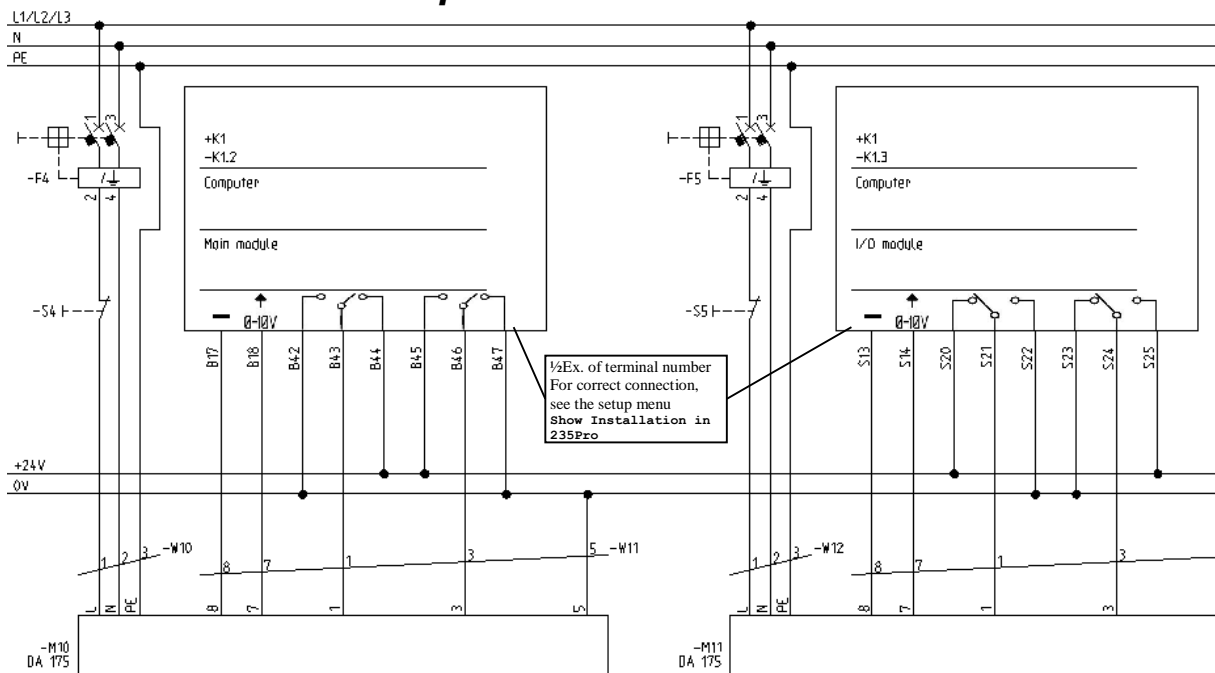

### 5.6.8 Two CL 74BC

Two CL 74BC motors for air inlet  
See diagram 5.6.4 CL 74BC 24 V

### 5.6.9 Two CL 75A 24 V

Two CL 75A motors for air inlet  
See diagram 5.6.1 CL 75A 24 V

### 5.6.10 Two CL 174 24 V

Two CL 174 motors for air inlet  
See diagram 5.6.2 CL 174 24 V

### 5.6.11 Four CL 75A 24 V

Four CL 75A motors for air inlet  
See diagram 5.6.1 CL 75A 24 V

### 5.6.12 Four CL 174 24 V

Four CL 174 motors for air inlet  
See diagram 5.6.2 CL 174 24 V

For correct connection of several winch motors, see the setup menu **Show Installation** in 235Pro.

### 5.6.13 CL 75A 24 V Combi-Diffuse on/off

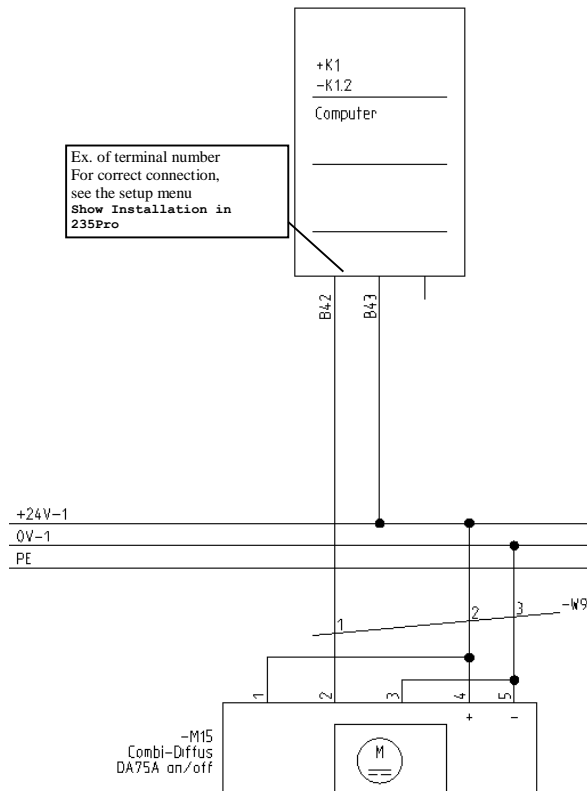

Cable dimensions for 24V DC motors depending on length	
24 V DC	
Length < 70 m	7 x min. 1,0 mm <sup>2</sup>
70 < Length < 100 m	7 x min. 1,5 mm <sup>2</sup>
100 < Length < 165 m	7 x min. 2,5 mm <sup>2</sup>
165 < Length < 265 m	7 x min. 4,0 mm <sup>2</sup>

### 5.6.14 CL 174 24 V Combi-Diffuse on/off

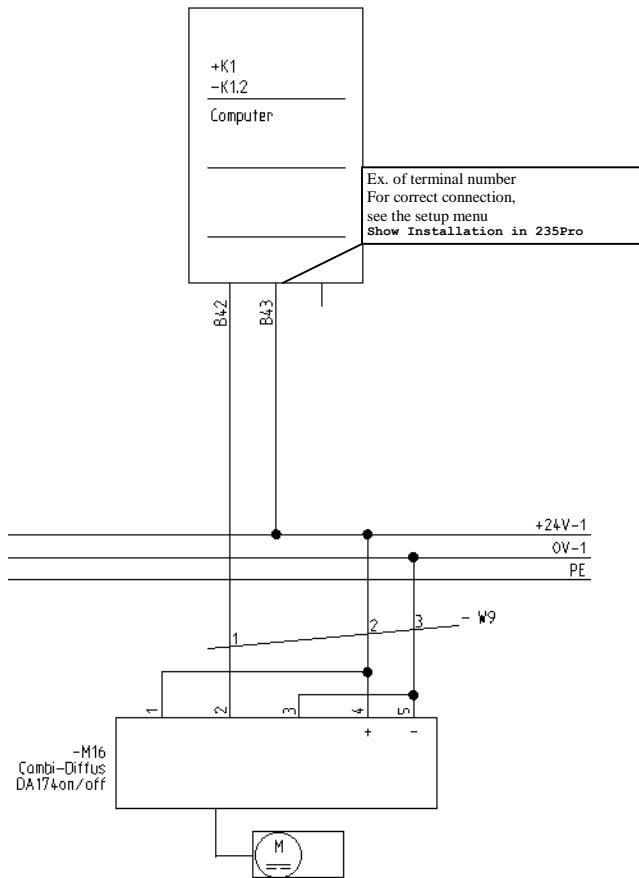

Cable dimensions for 24V DC motors depending on length	
24 V DC	
Length < 7 0m	7 x min. 1,0 mm <sup>2</sup>
70 < Length < 100 m	7 x min. 1,5 mm <sup>2</sup>
100 < Length < 165 m	7 x min. 2,5 mm <sup>2</sup>
165 < Length < 265 m	7 x min. 4,0 mm <sup>2</sup>

### 5.6.15 Combi-Diffuse Stepless

See diagram 5.6.1 CL 75A 24 V

See diagram 5.6.2 CL 174 24 V

See diagram 5.6.3 CL 75A 230 V

See diagram 5.6.5 CL 74CV Stepless

## 5.7 Winch Motors for Air Outlet

### 5.7.1 CL 74CV Stepless

NOTE: In house 2, move L1 to L2

(the fixed phase must be the same for the winch motor and speed control).

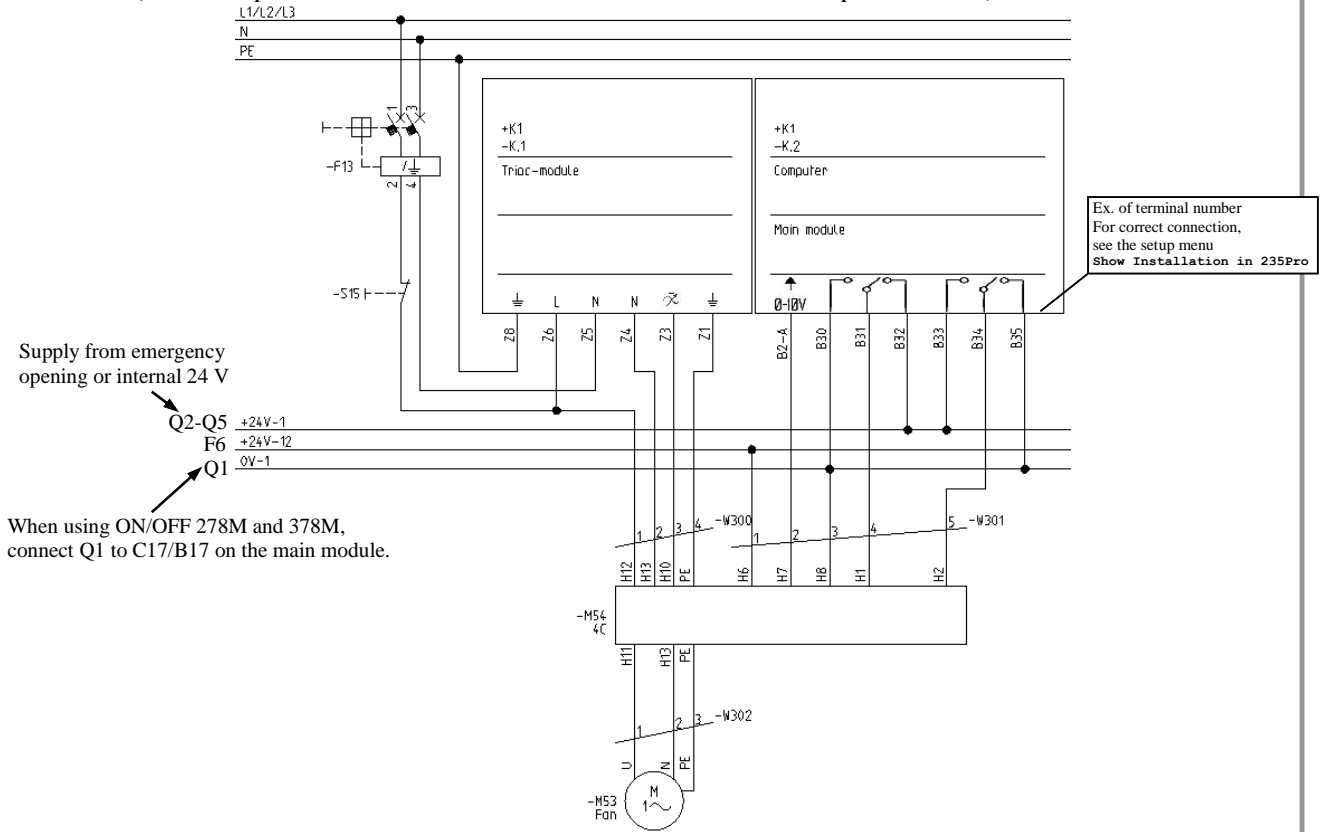

### 5.7.2 Two CL 74CV Stepless

For correct connection of several winch motors, see the setup menu **Show Installation in 235Pro**

**Two CL 74CV stepless winch motors for air outlet**

See diagram 5.7.1 CL 74CV Stepless

### 5.7.3 CL 75A 24 V

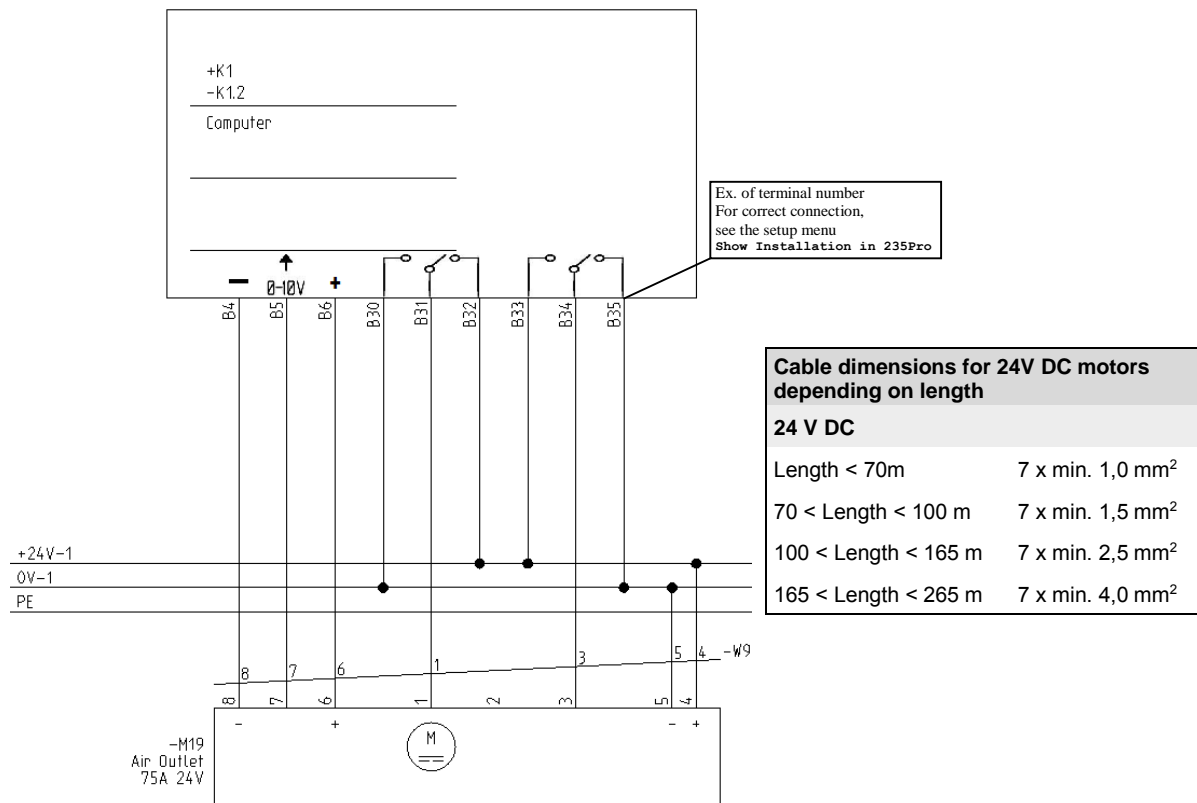

### 5.7.4 CL 75A 230 V

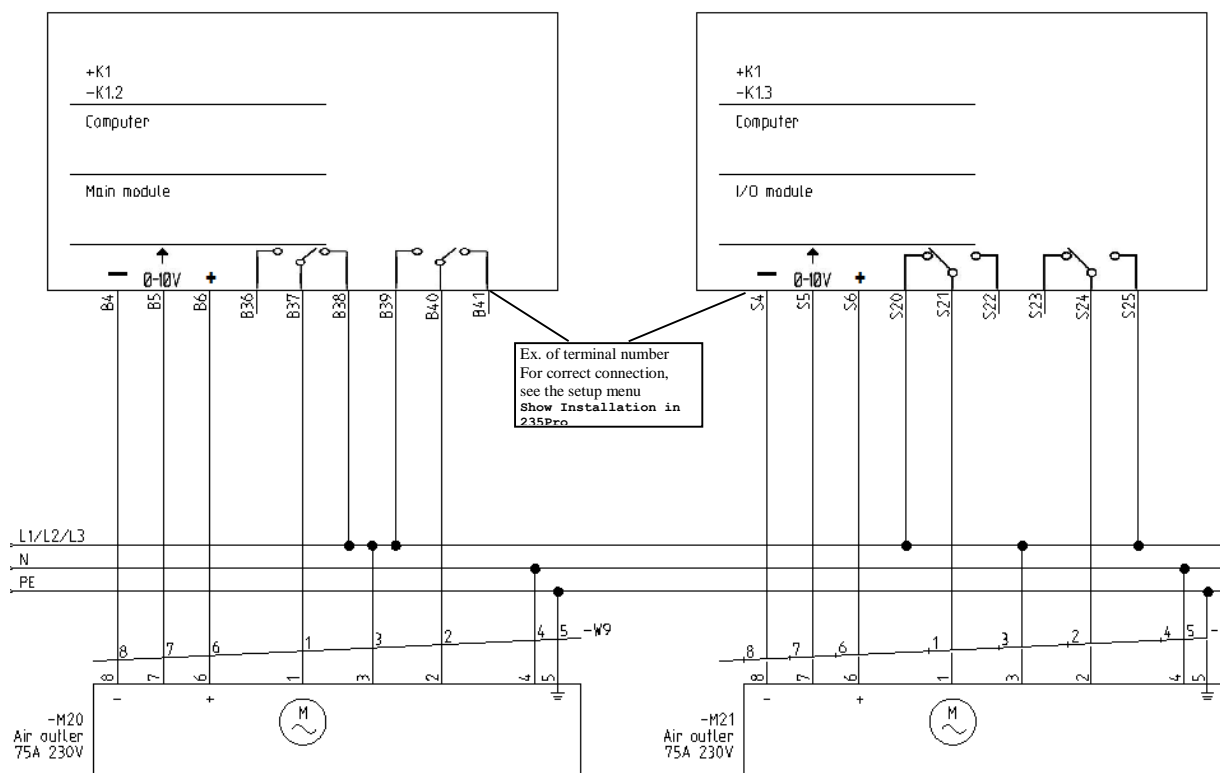

### 5.7.5 CL 74BC 24 V

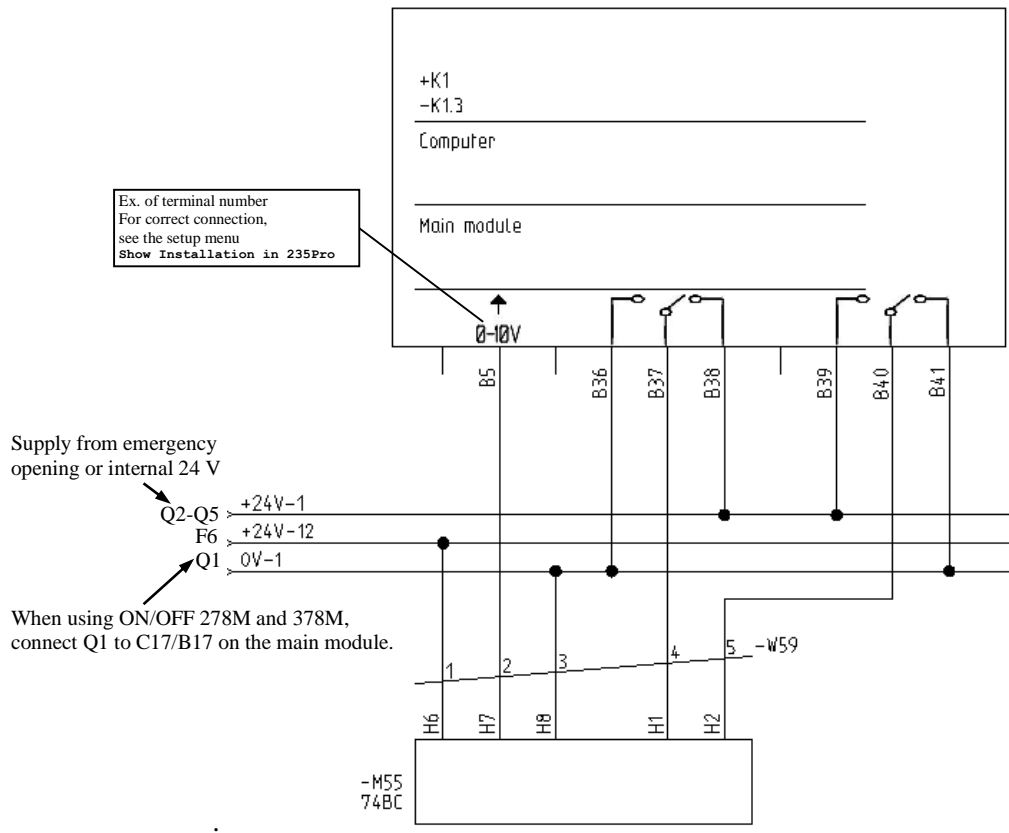



## 5.8 MultiStep®

### 5.8.1 Air Outlet one-phase

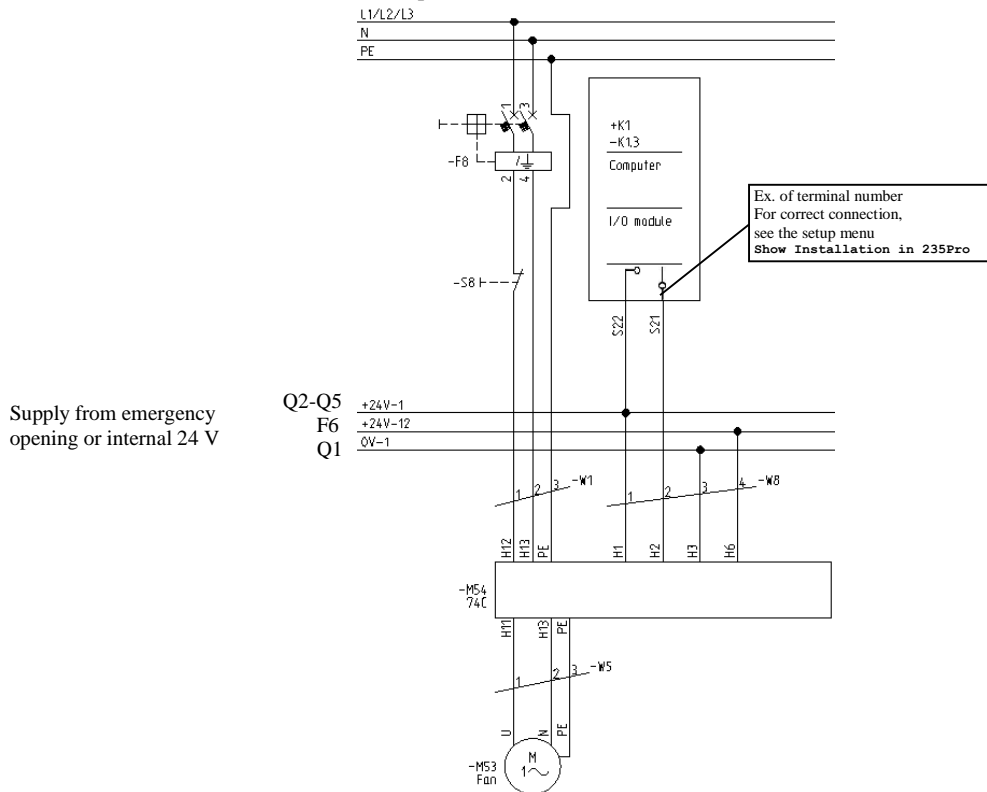

### 5.8.2 Air Outlet three-phase

Distribute the fans on phases L1, L2, L3.

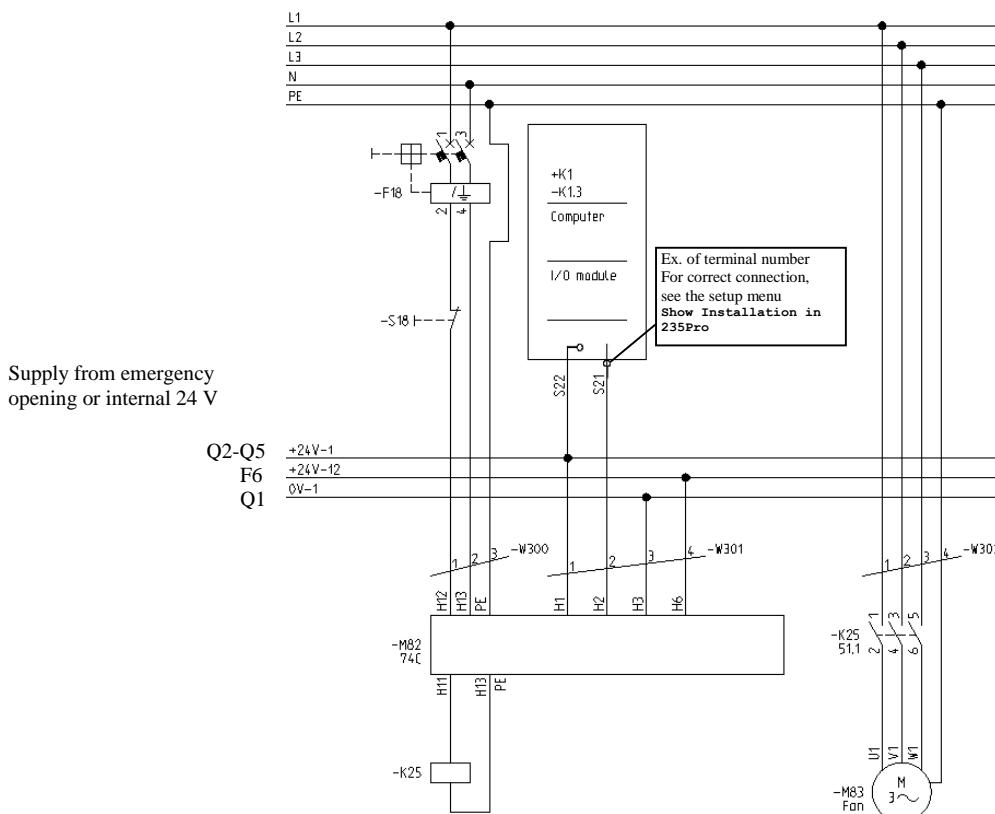

### 5.8.3 Gable Fan for Air Outlet

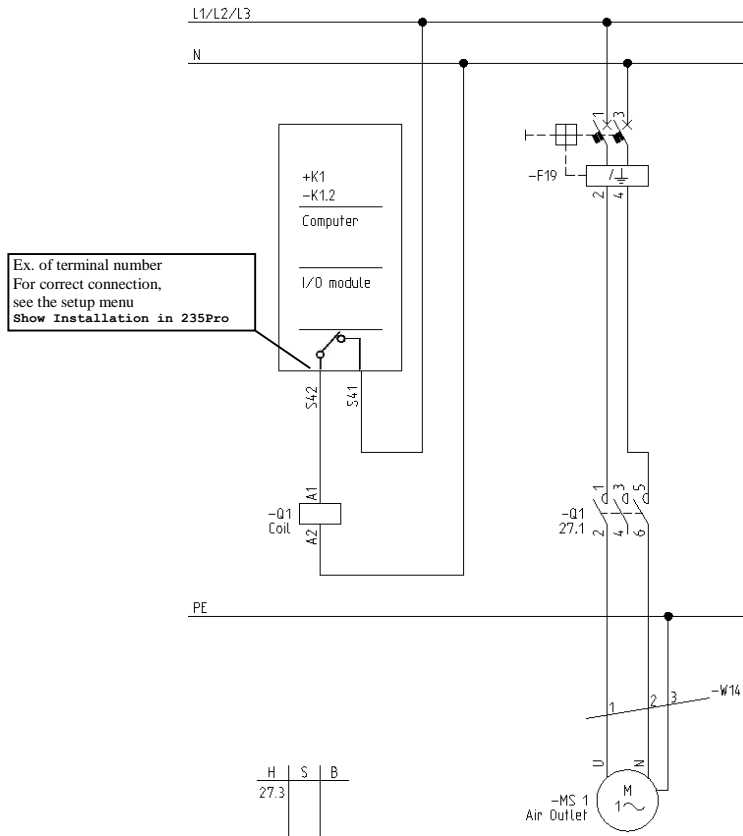

## 5.9 Dynamic MultiStep, AnySpeed

### 5.9.1 Air Outlet CL 74CO ON/OFF to CL 600 LPC

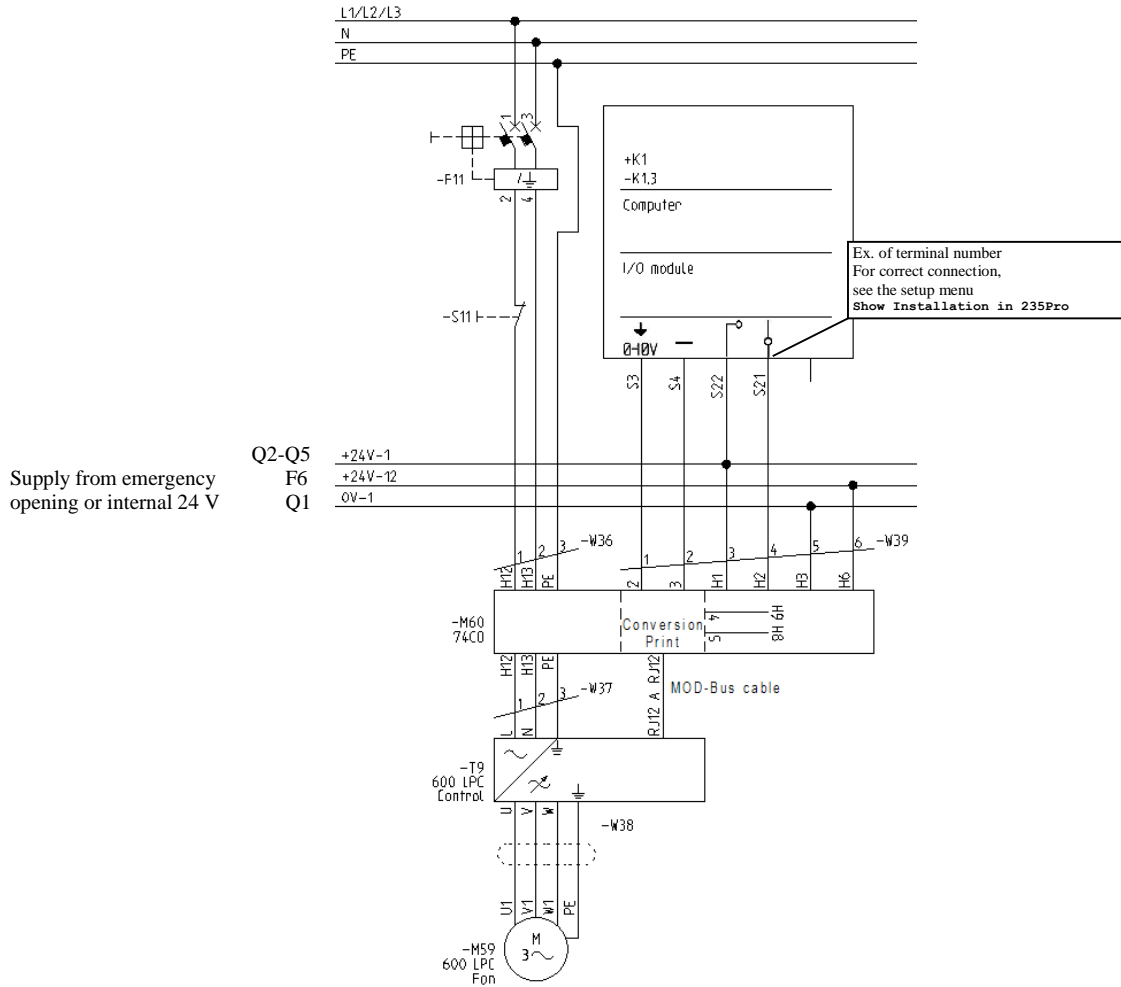

### 5.9.2 Air Outlet several fans

Distribute the fans on phases L1, L2, L3.

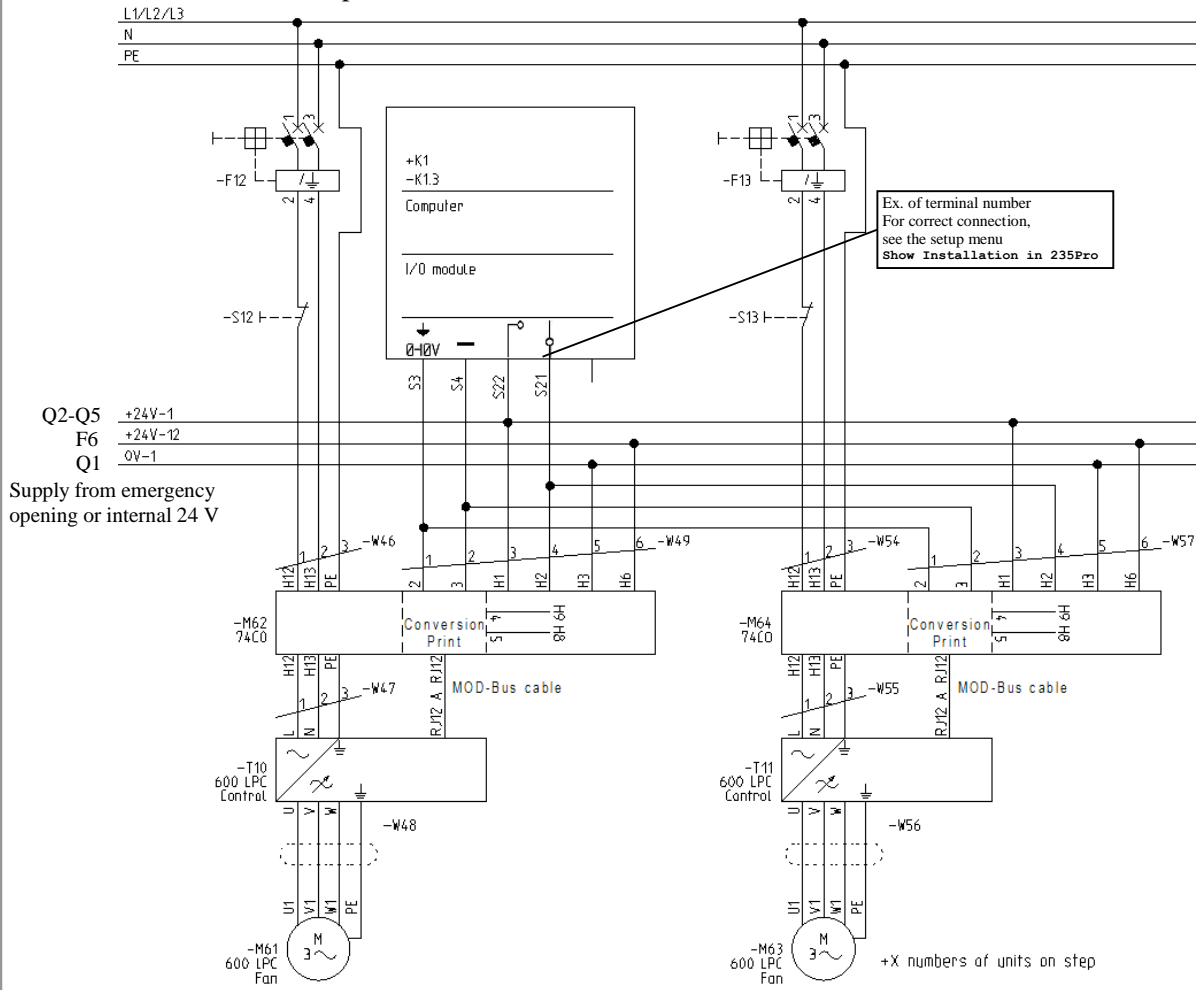

### 5.9.3 Air Outlet CL 74CV Stepless to CL 600 LPC

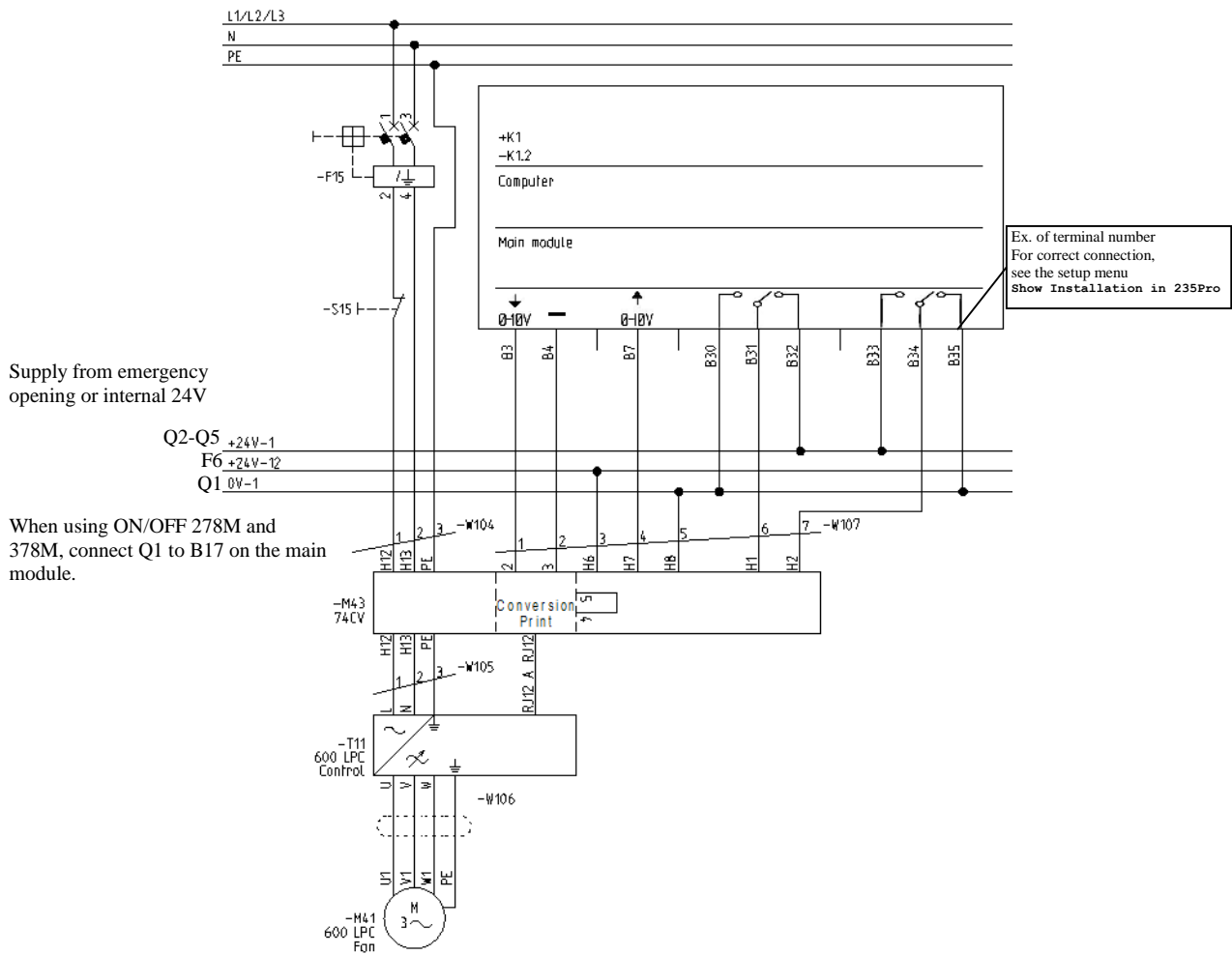

### 5.10 Dynamic MultiStep, DualSpeed

With stop relay when free range or natural ventilation is used.

#### 5.10.1 Air Outlet CL 74CO ON/OFF to CL 600 LPC

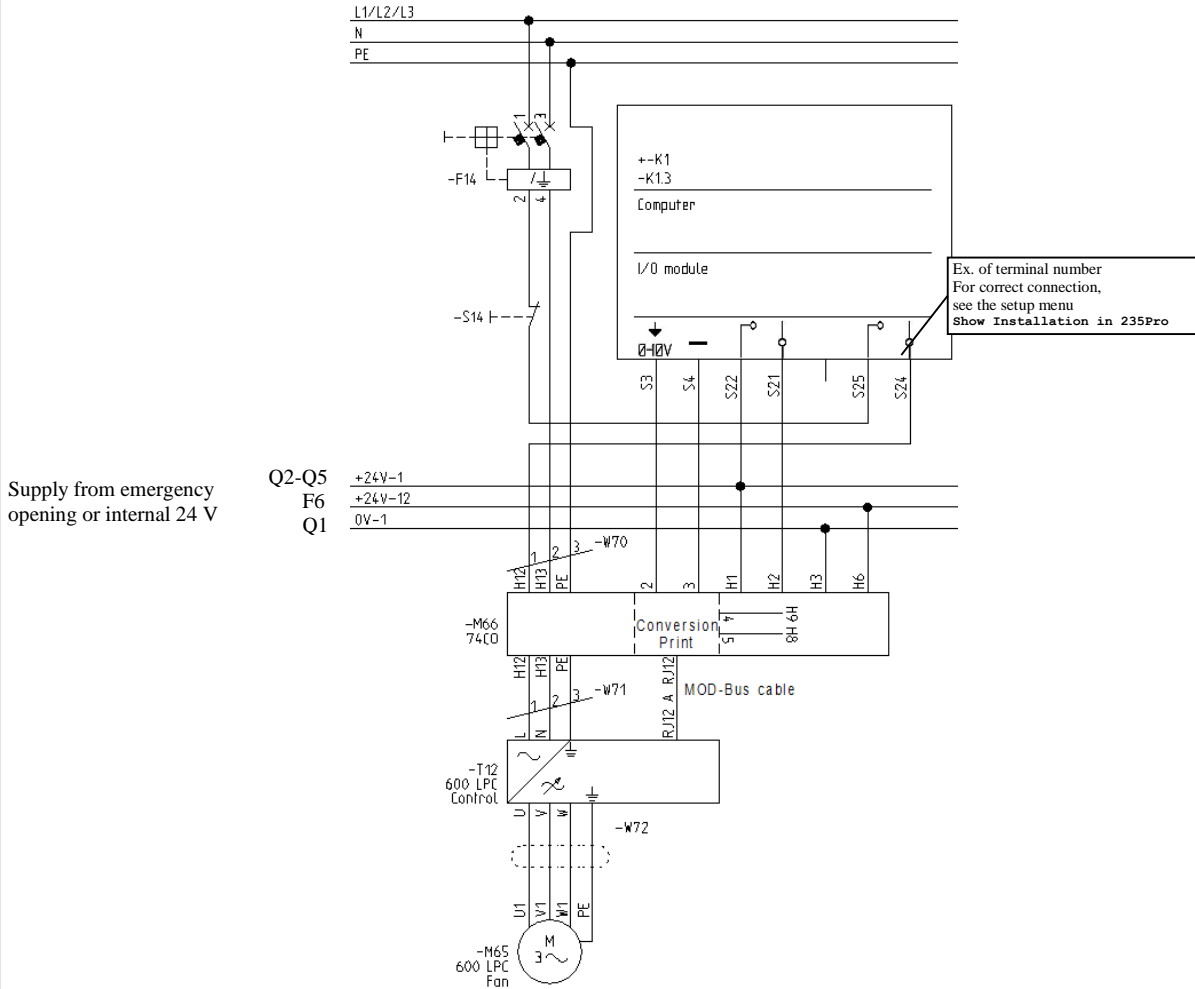

### 5.10.2 Air Outlet several fans

With stop relay when free range or natural ventilation is used.

Distribute the fans on phases L1, L2, L3.

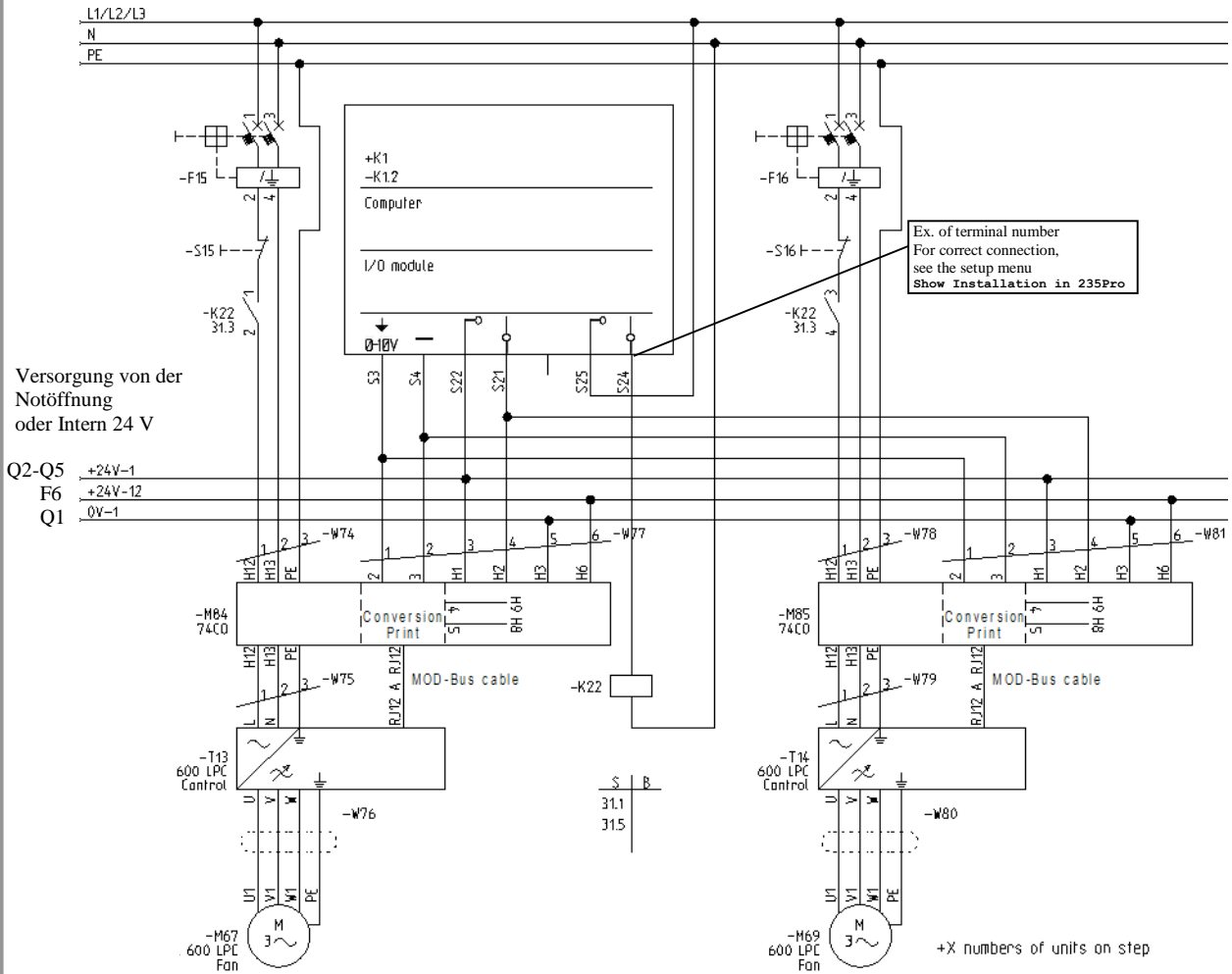

### 5.10.3 Air Outlet CL 74CV Stepless to CL 600 LPC

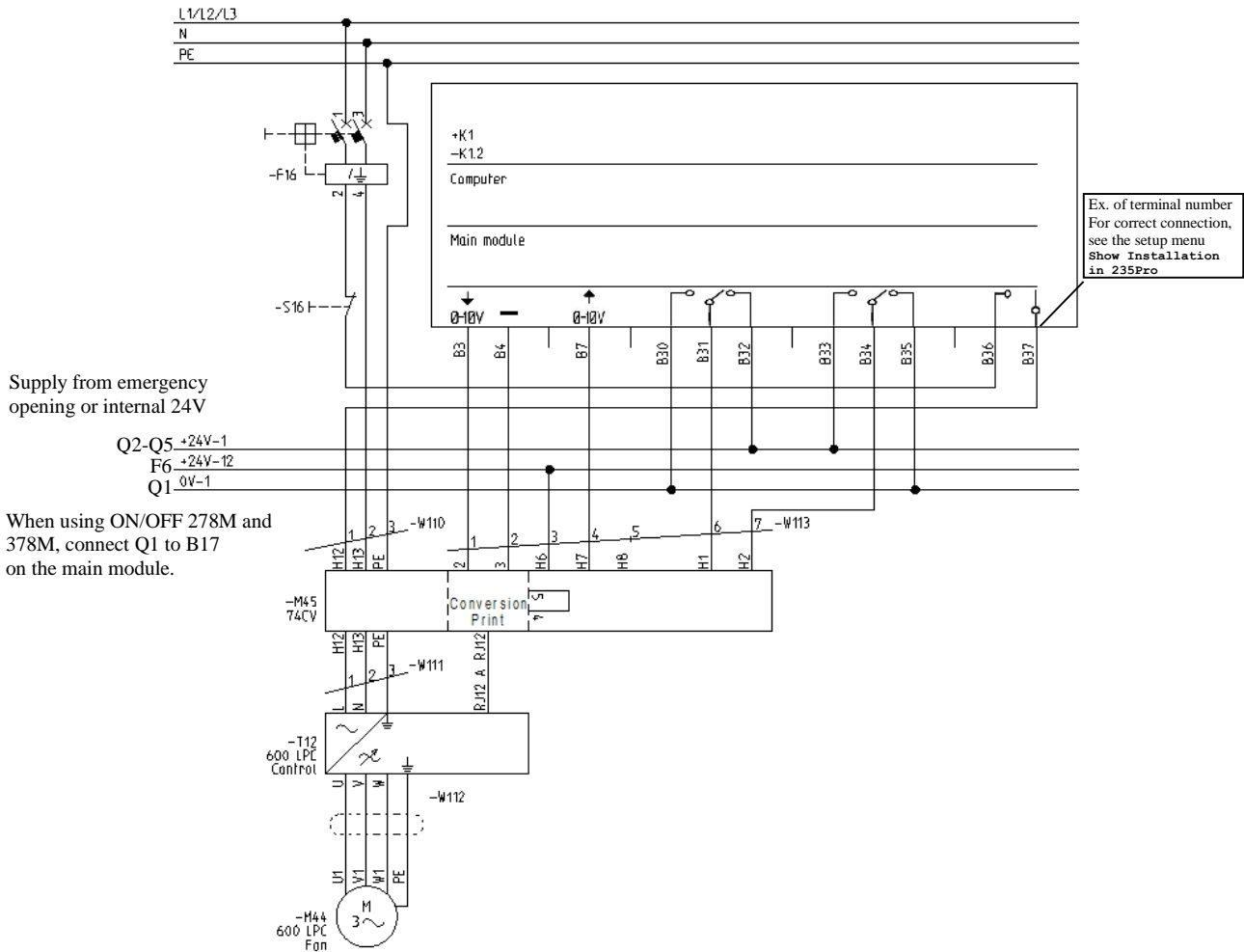



## 5.11 Room/Floor Heating

### 5.11.1 0-10 V Analogue

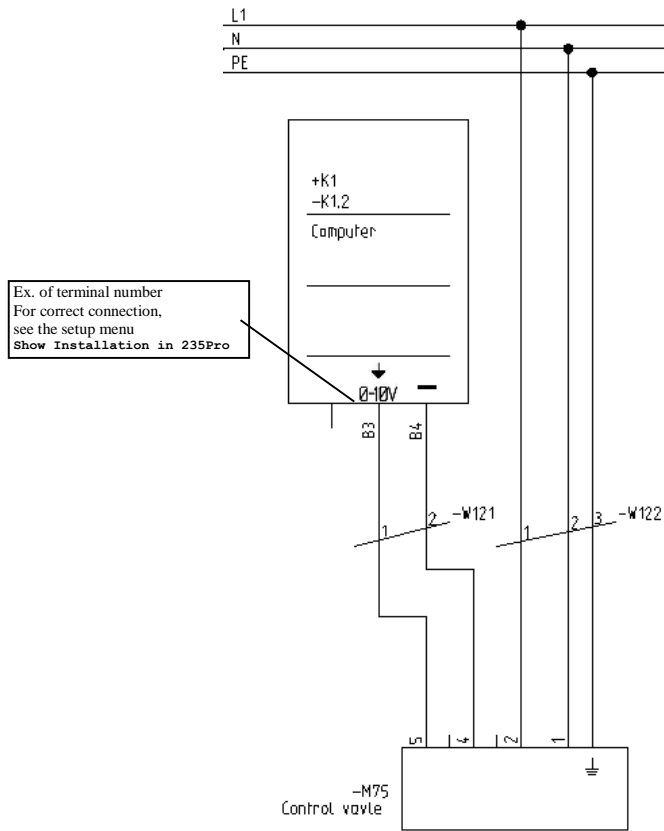

### 5.11.2 Relay Heating (Solenoid Valve)

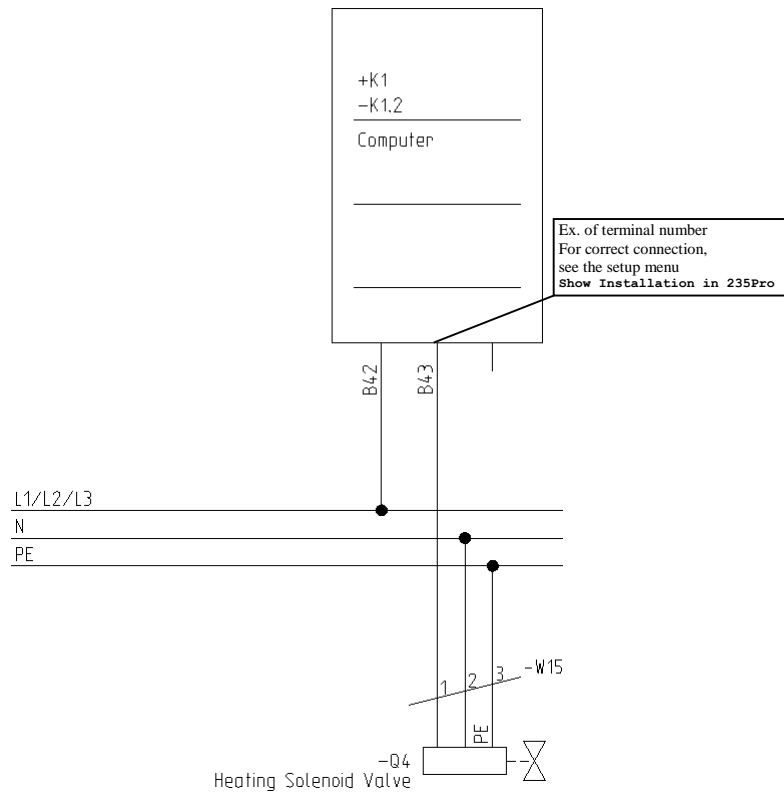

### 5.11.3 Blowheater and stir fan

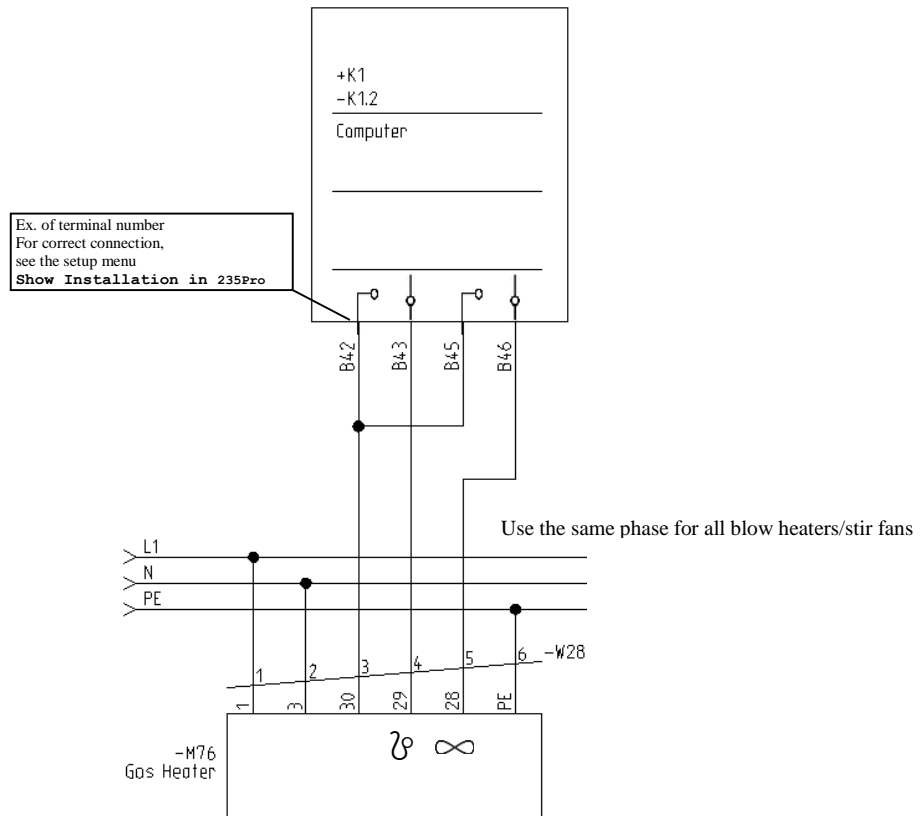

### 5.11.4 Relay Heating 3-phase

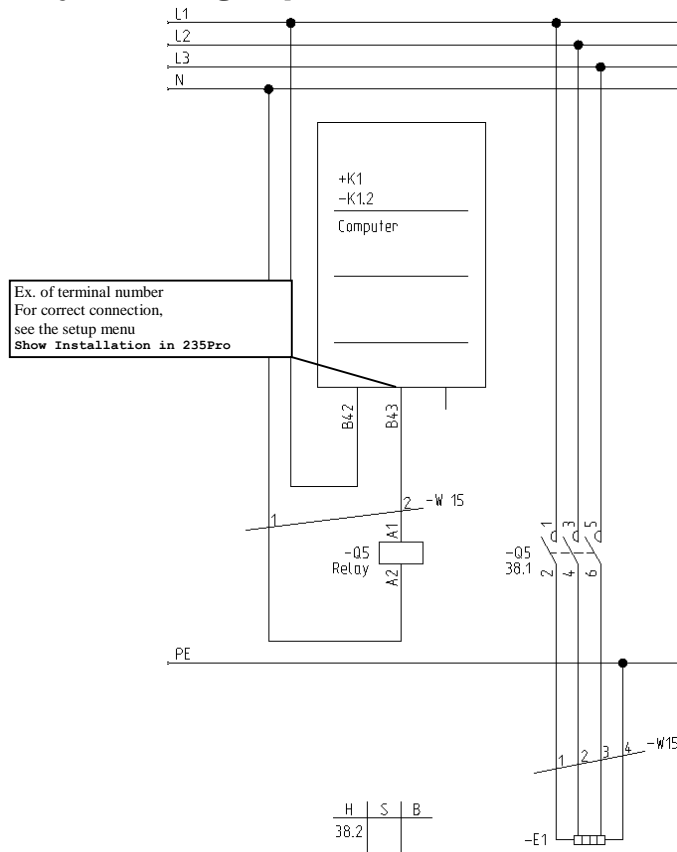

## 5.12 Special Connections

### 5.12.1 Common Exhaustion 0-10 V

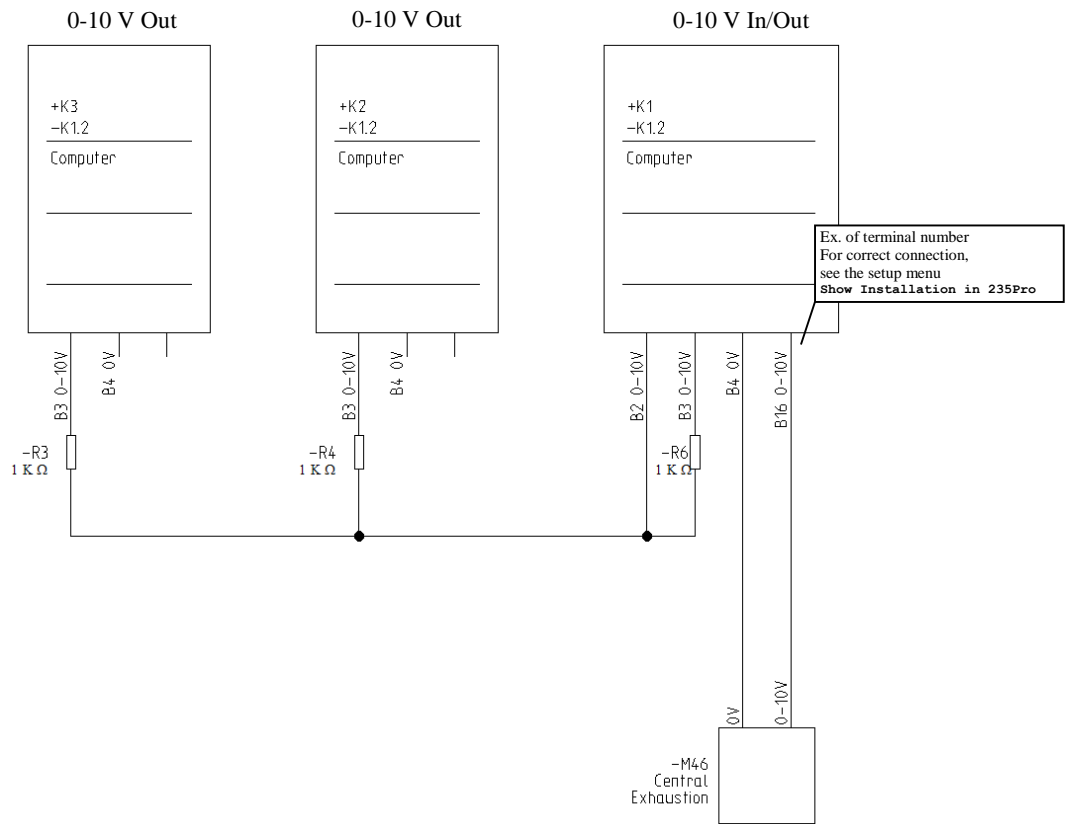

### 5.12.2 Differential Pressure Meter

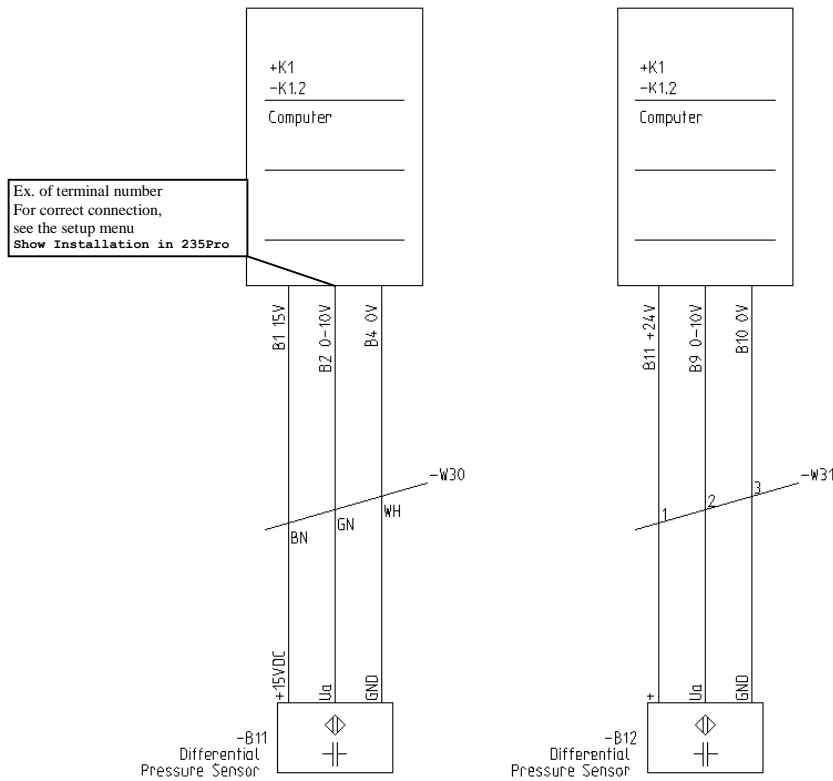

### 5.12.3 Cooling/Humidification/Soaking

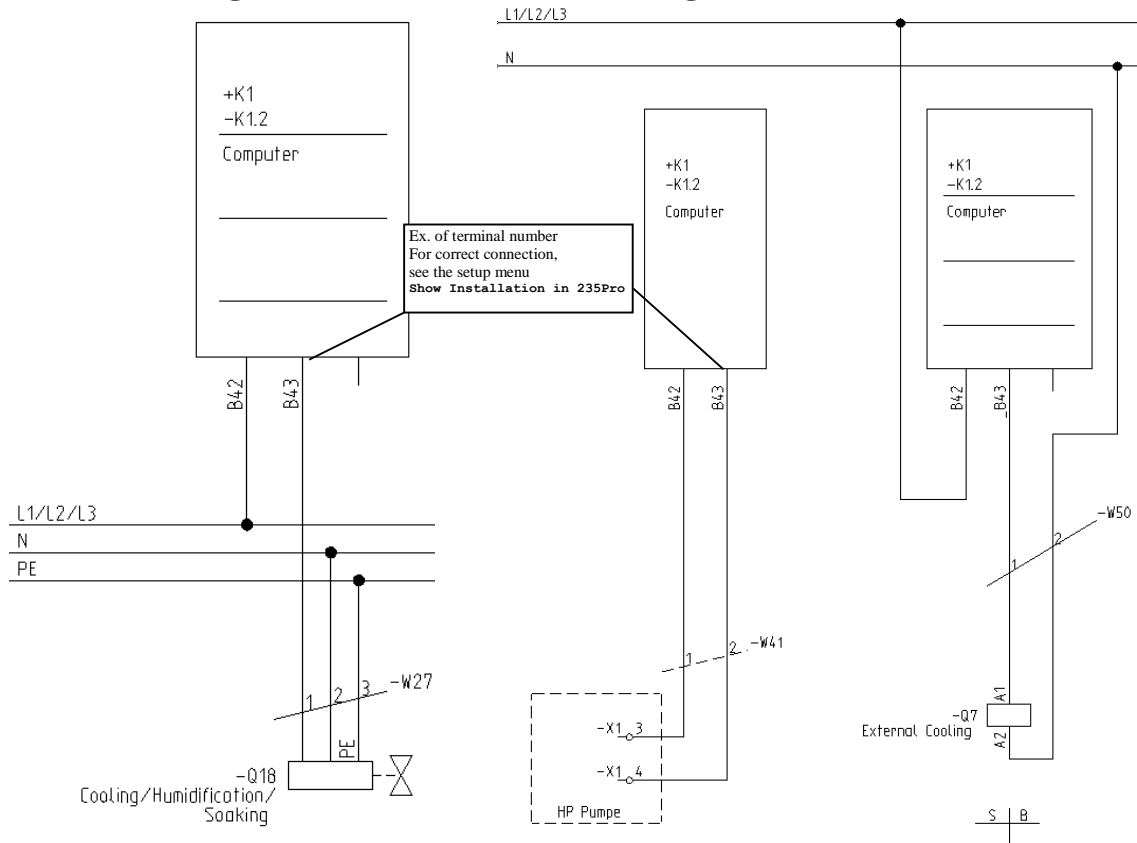

### 5.12.4 Spraying/Environmental Function

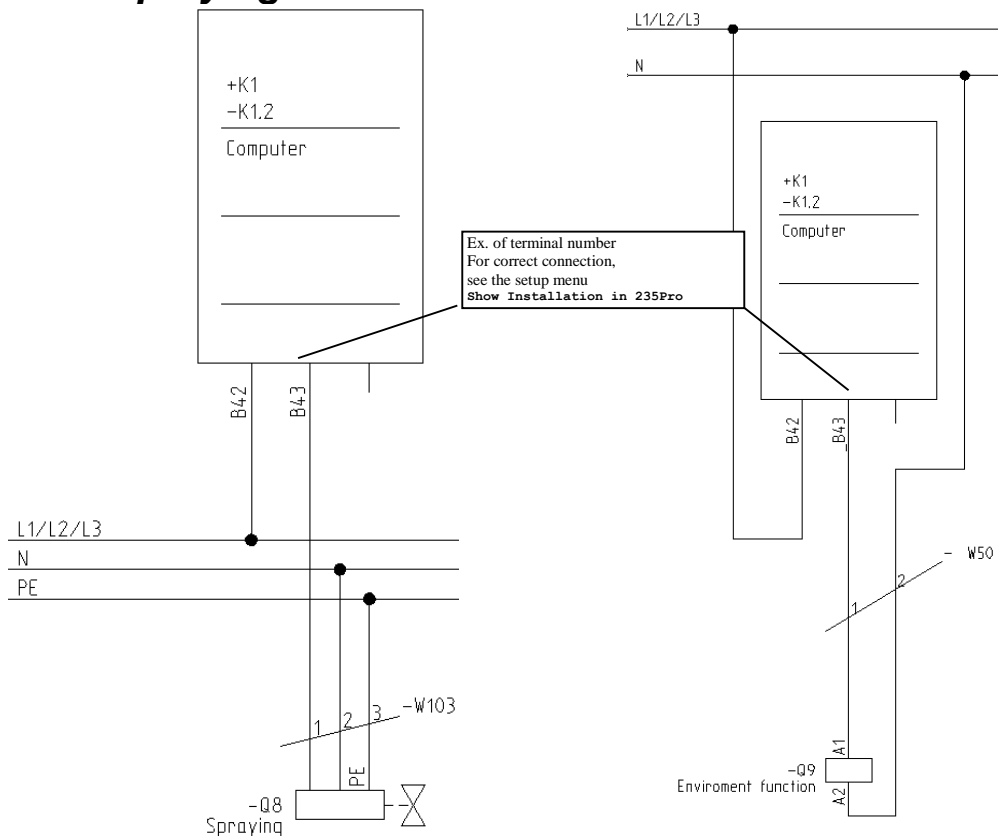

### 5.12.5 Free Range/Catching Function

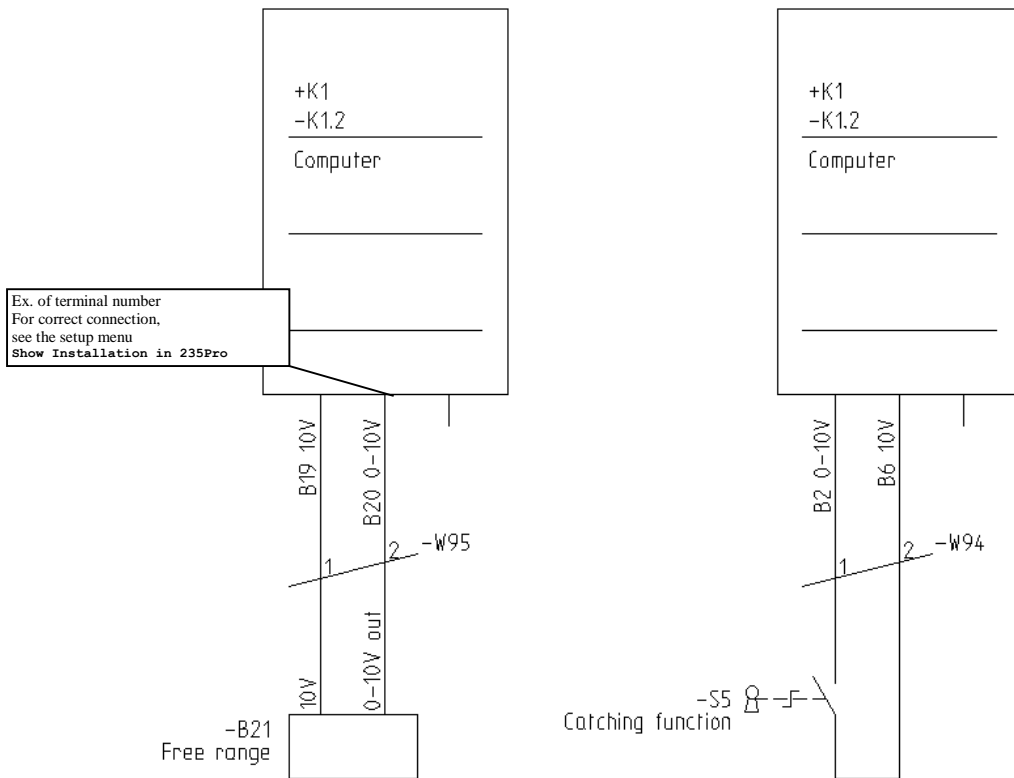

### 5.12.6 24-hour Clock/Water Meter

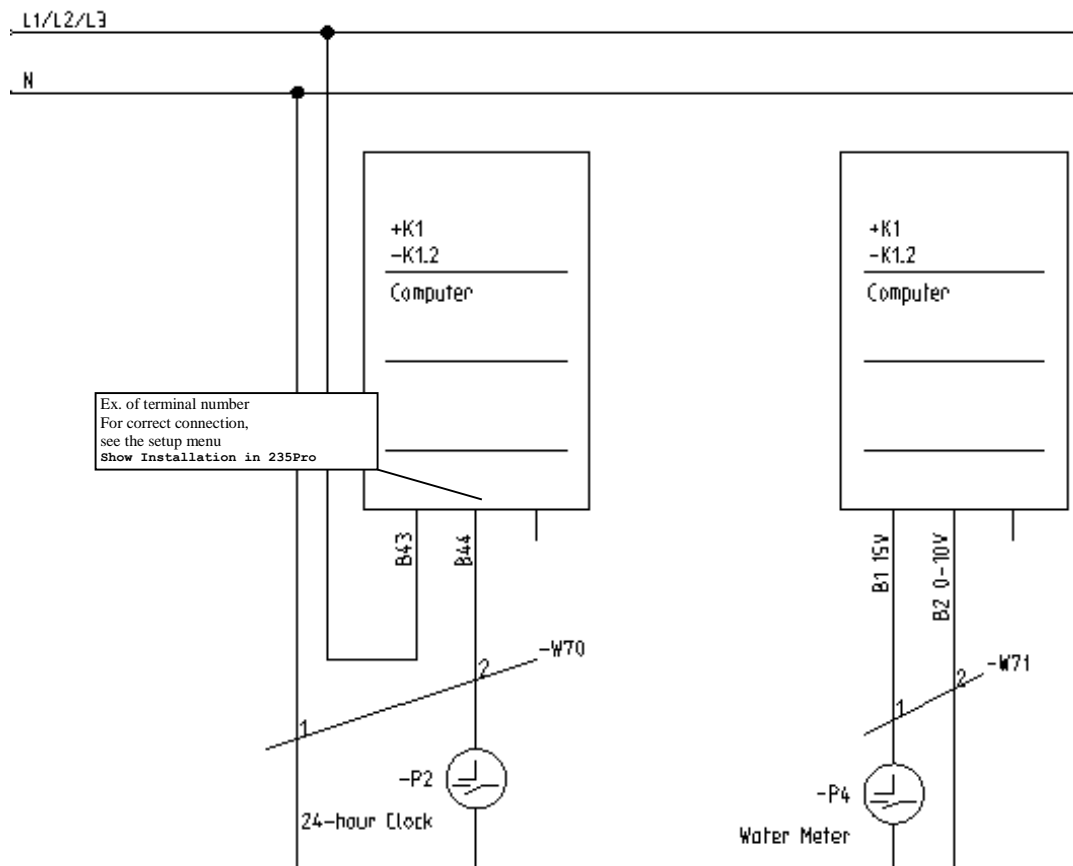

### 5.13 Emergency Air Intake

#### 5.13.1 CL 74BC ON/OFF Winch Motor

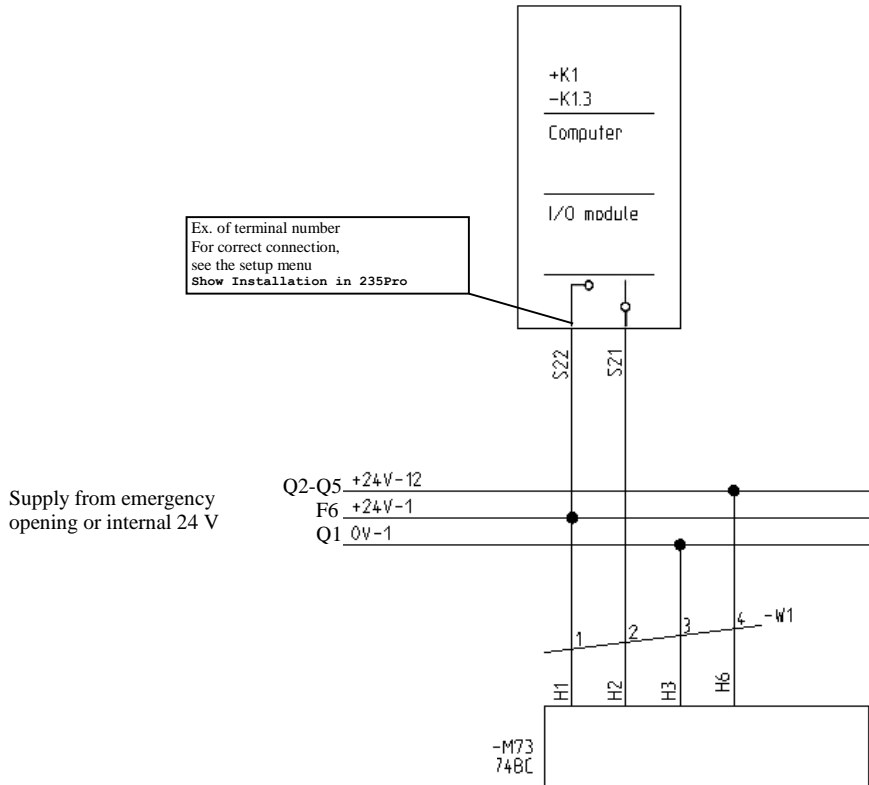

#### 5.13.2 CL 75A 24 V Winch Motor

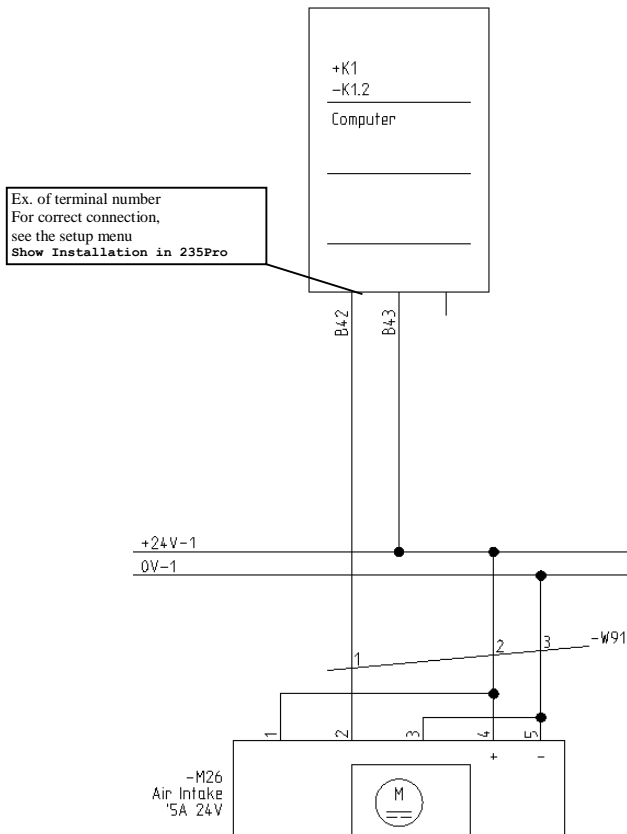

Cable dimensions for 24V DC motors depending on length	
24 V DC	
Length < 70 m	7 x min. 1,0 mm <sup>2</sup>
70 < Length < 100 m	7 x min. 1,5 mm <sup>2</sup>
100 < Length < 165 m	7 x min. 2,5 mm <sup>2</sup>
165 < Length < 265 m	7 x min. 4,0 mm <sup>2</sup>

### 5.13.3 CL 174 (24 V) Winch Motor

Ex. of terminal number  
For correct connection,  
see the setup menu  
**Show Installation in 235Pro**

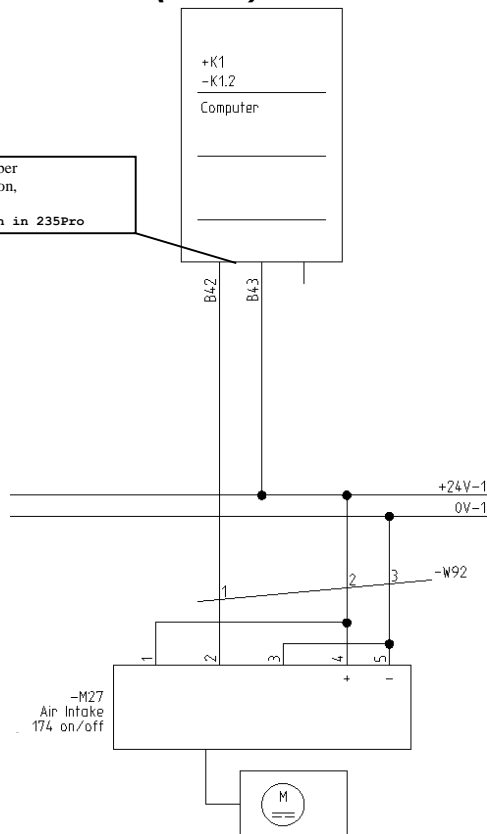

**Cable dimensions for 24V DC motors depending on length**

**24 V DC**

Length < 70 m	7 x min. 1,0 mm <sup>2</sup>
70 < Length < 100 m	7 x min. 1,5 mm <sup>2</sup>
100 < Length < 165 m	7 x min. 2,5 mm <sup>2</sup>
165 < Length < 265 m	7 x min. 4,0 mm <sup>2</sup>

### 5.13.4 Solenoid Valve 230 V

Ex. of terminal number  
For correct connection,  
see the setup menu  
**Vis Installation i235Pro**

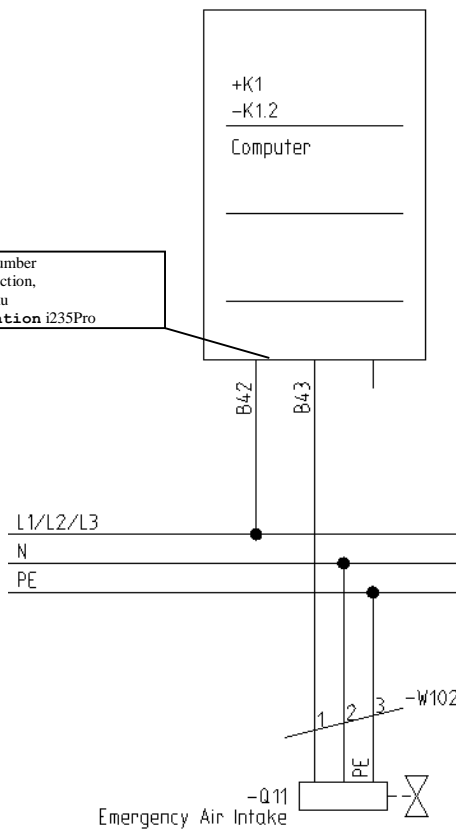

## 5.14 Connection to Equal Pressure System

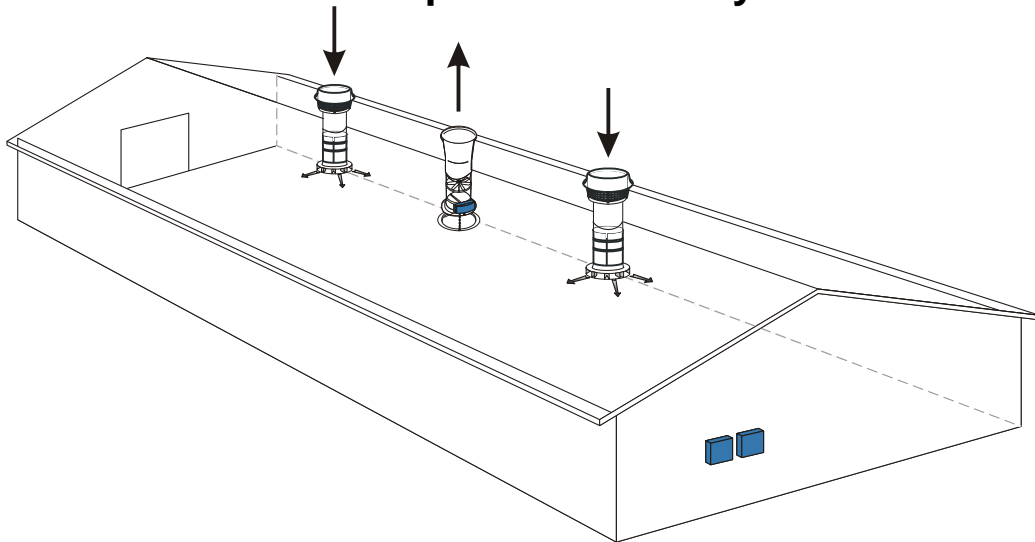

### 5.14.1 Equal Pressure System: MultiStep®

#### Injection

Connect the air supply fans in **Air inlet 1 fan**.

#### External speed control

See diagram 5.4 External Speed Control

If there is no air inlet speed control, install the air inlet and air outlet on the *same* speed control: **Air inlet** / Speed control 1.

#### Internal speed control

See diagram 5.3 Internal Speed Control

Two Parallel Fans

#### Air inlet (winch motor)

See diagrams section 5.6. Winch Motors for Air Inlet

#### Recirculation

Connect the recirculation fans to **Air inlet 2 fan**.

#### Air outlet

Connect the air outlet as an ordinary MultiStep®.  
See diagram 5.8 MultiStep®



### **5.14.2 Equal Pressure System – with Inlet and Outlet on the same Speed Control**

#### **Inlet and outlet**

Connect the fans for both inlet and outlet in **Air outlet / Speed control 1**.

#### **External speed control**

See diagram 5.4 External Speed Control

#### **MC 31**

#### **Air inlet (winch motors)**

See diagrams section 5.6. Winch Motors for Air Inlet

#### **Air outlet (winch motors)**

See diagrams section 5.7 Winch Motors for Air Outlet

#### **Recirculation**

Connect the recirculation fans to **Air inlet 2 fan** on the internal speed control.

#### **Internal speed control**

See diagram 5.3 Internal Speed Control





