

# Product information



**Big Dutchman**

Big Dutchman International GmbH  
Big Dutchman Pig Equipment GmbH  
P.O. Box 11 63 · 49360 Vechta · Germany  
Tel. +49(0)44 47-801-0 · Fax 801-237  
big@bigdutchman.de · www.bigdutchman.de

No. 1285      July 17, 2012

## New ESF station Call-Inn

The electronic sow feeding station „Call-Inn“ is a new addition to our product range of feeding stations and will be available in addition to the CallMatic ESF station. The development of the new station has been completed and it is now ready for delivery.

The development of this particular feeding station became necessary because competition in the worldwide markets is rather tense. It is especially important for Big Dutchman to be able to offer an alternative in the lower price segment. Call-Inn is this new economic solution.

Call-Inn was developed and designed particularly for stable large groups with up to 60 pigs per group.



65-00-2250

Feed station dry left wo/selection CI/ESF

The following table lists the features of Call-Inn and Callmatic in comparison:

	<b>CallMatic</b>	<b>Call-Inn</b>
Entrance	pneumatic	pneumatic
Door	trough flap	trough flap
Trough material	stainless steel	stainless steel
Entire structure	galv. metal	galv. metal
Station selection	pneumatic	none
Colour marking	3	1
Feed types	2	1
Minerals	1	-
Heat detector	X	X
Dry feeding	X	X
Liquid feeding	X	-
Control system	BigFarmNet	BigFarmNet
Delivery	pre-mounted	assembly kit

In general:

**Dynamic groups = Callmatic**  
**Stable groups = Call-Inn or Callmatic**

The following production systems are suited for stable groups and therefore for the use of the Call-Inn or the Callmatic without selection:

**1-week rhythm with**

- 1,000-1,200 productive sows with 21 days of nursing (1 station per group)
- 1,100-1,300 productive sows with 28 days of nursing (1 station per group)
- 2,400-2,600 productive sows with 21 days of nursing (2 stations per group)
- 2,500-2,700 productive sows with 28 days of nursing (2 stations per group)

**2-week rhythm with**

- 500-600 productive sows with 21 days of nursing (1 station per group)
- 600-700 productive sows with 28 days of nursing (1 station per group)
- 1,000-1,200 productive sows with 21 days of nursing (2 stations per group)
- 1,200-1,400 productive sows with 28 days of nursing (2 stations per group)

### 3-week rhythm with

350-450 productive sows with 21 days of nursing (1 station per group)

350-450 productive sows with 28 days of nursing (1 station per group)

700-900 productive sows with 21 days of nursing (2 stations per group)

700-900 productive sows with 28 days of nursing (2 stations per group)

The following option is available for the feeding station:

- Colour-marking (max. 1 colour)

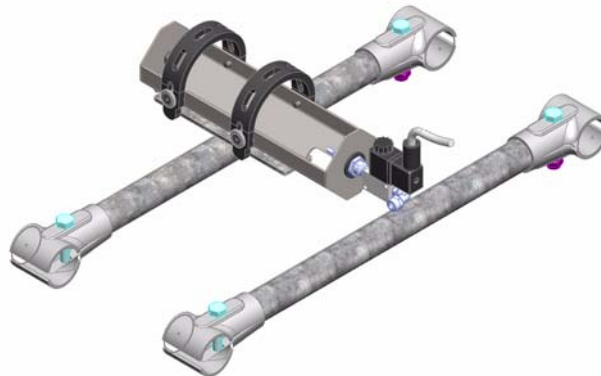

65-00-2252	Colour marking feeding station CI/ESF
------------	---------------------------------------

The Call-Inn comes with BigFarmNet control. All control elements and sensors are included in the following component groups:

65-00-2251	Station control unit for feeding station Call-Inn BFN
91-02-6541	Licence MC505 - BigFarmNet CI/ESF - sales version

In addition to the above mentioned items the feeding station requires a working network and a compressed-air supply.

Also include one licence per Call-Inn when preparing the tender.

All required parts can be found in the respective planning & projecting aid available in the Infothek.

If you have any questions, don't hesitate to contact the product management team. We will gladly assist you with the integration of the Call-Inn in different projects and with tender preparation.

Daniel Holling  
- Product manager Call-Inn -

Karsten Fuchs  
- Design engineering Call-Inn -