

PIONEER IN
PLASTIC SANDWICH PANELS



**LIGHT
STRONG
CLEAN**



PANELTIM®



PANELTIM® PRODUCTION PROCESS

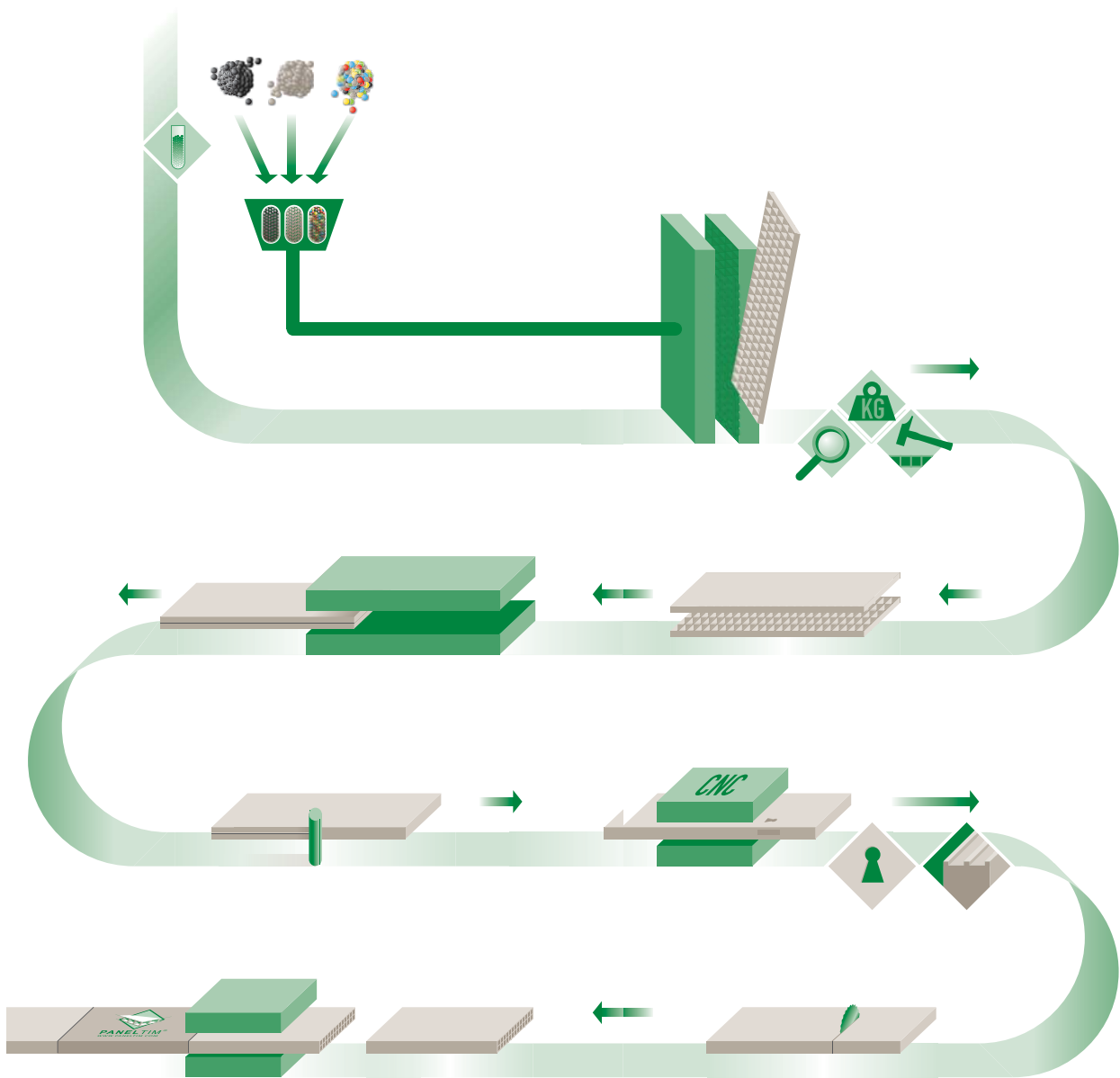

PANELTIM® PIONEER IN SANDWICH PANELS

Paneltim® panels produced by specialists, for specialists.

Paneltim NV is a family-owned company in Lichtervelde (Belgium) which processes thermoplastics for the **production of sandwich panels** and slats. Paneltim is the world's independent market leader in plastic sandwich panels made by injection and mirror welding.

Different fabrication techniques are used for the production of the plastic sandwich panels, namely: high-pressure injecting (1600, 1850, 3000 and 4000 tons clamping force), semi-compression moulding (2000 tons clamping force), low-pressure injecting (1000 tons clamping force), mirror welding, cutting and CNC controlled milling.

In the agricultural sector, the panels are used as pen dividers, pen doors, corridor and compartment walls, personnel doors for pig buildings and many other applications.

The polypropylene (PPCO) panels meet the highest hygienic requirements for animal housing, as the panels are closed all around to repel water and dirt.

Our daily challenge is to **innovate, in order to optimize quality and to search for product possibilities** together with our customers.

Through our global network, we challenge and assist our customers in diverse sectors to develop as many strong and creative applications as possible.

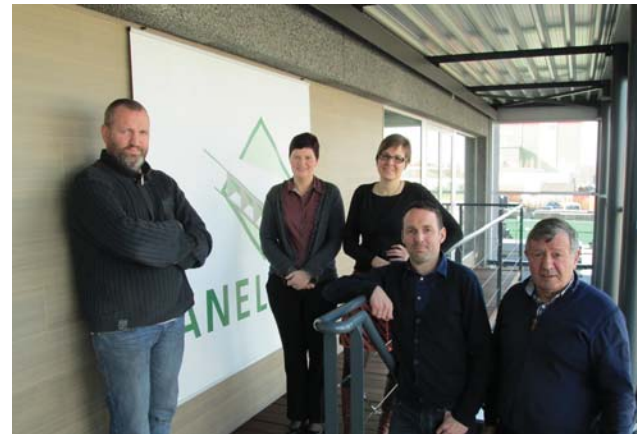

PANELTIM® SANDWICH PANEL IN PPCO

Animal housing and hygienic rooms

Paneltim® panels are made of polypropylene copolymer (PPCO) and are coloured in the mass. The panels are light, solid, rigid and ideal for animal housing and hygienic rooms.

Sandwich structure

The panels have a thickness of 50, 35 or 20 mm and have a sandwich structure. Due to their unique internal cell structure with ribs of 50/50mm or 50/100mm, they are very solid and strong in both length and width.

Optimal hygiene

The internal cell structure ensures that all the sides of the panel are always closed (even with customized work) in order to repel dirt, water or other substances inside the panels. They can be cleaned quickly and easily with high pressure water as their surface is smooth, non-absorbing, water- and dirt-repelling and dries fast.

Easy manipulation

Standard Paneltim® panels can be cut and made into any dimension by hot mirror welding. Next to hot mirror welding, the panels are easy to connect using a hot air welding machine. As the panels are lightweight, large size one-piece panels can be mounted quickly and easily.

Less reinforcements

Thanks to their internal structure, the panels require less reinforcements compared to other materials, which enables smooth assembly.

No Aging

PPCO preserves its elasticity through the years. Paneltim® panels assure excellent mechanical characteristics and good chemical features for numerous applications. They have good impact resistance and are highly resistant to dynamic shocks. The panels do not discolour, even in contact with ammonia.

Insulation

The panels have a high insulation value due to the low thermal conduction of plastic and the hermetically enclosed air in the cells.

Ecological

Paneltim® panels are made of prime or recycled raw materials. They are 100% recyclable, so there is no loss of raw material value. The panels are non-toxic and meet the European directive 2002/95/EC. In case of renovation, they can be reused.



Fire class

According to EN ISO 11925-2, the panels are classified under fire class E. Upon request, the panels can have an improved fire retardant resistance through the addition of flame retardants.



EXTENDED PRODUCT RANGE 50/100 SANDWICH PANELS

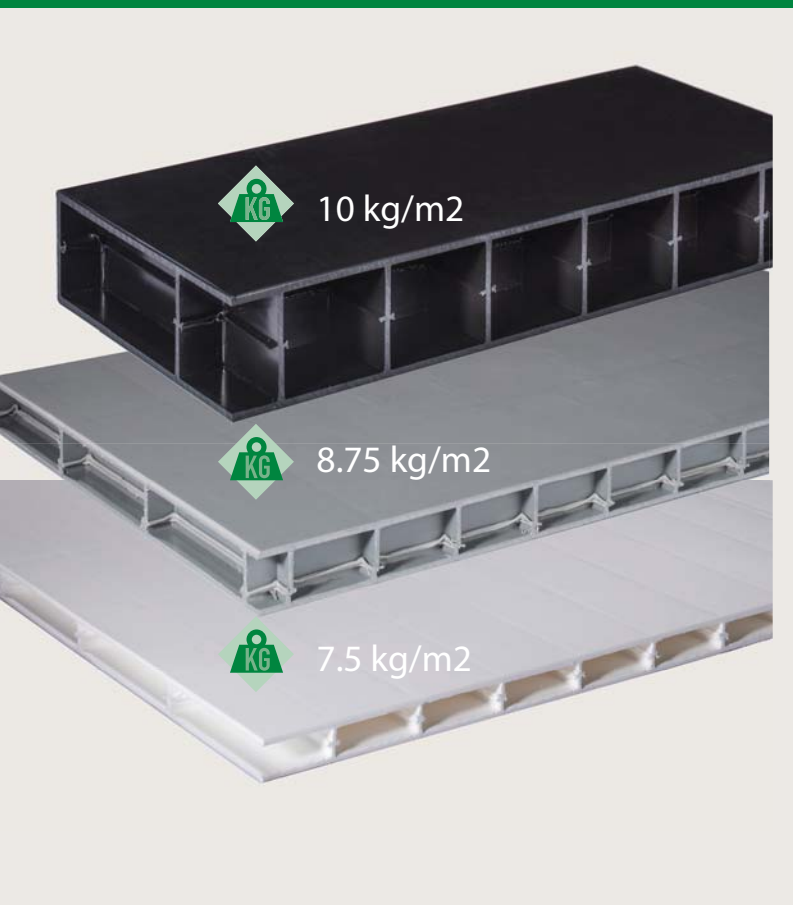

◆ Cell structure

- 50/100mm

◆ Smooth surface, wall thickness 3.5mm

◆ Standard dimensions 50mm

- 2600x1000 mm

- 1200x1000 mm

- 1200x800 mm

◆ Standard dimensions 20 and 35 mm

- 1200x1000 mm

- 1200x800 mm

◆ Standard colours *

- White (RAL 9010)

- Light grey (RAL 7001)

- Blue (RAL 5002)

- Green

- Black

* Other colours on demand (minimum order quantity)

Thanks to the wide range of thicknesses and structures, Paneltim® can offer a solution for any application, answering to your specific wishes.

We are proud to present two novelties which unlock interesting perspectives for new applications

- Paneltim® panel 20mm
- Paneltim® panel 35mm

These hygienic plastic panels preserve the advantages of the 50mm panels, but they are lighter and thinner, thus saving space. Though they are thinner, they have surprising characteristics on stiffness and bending.

Strength comparisons are available on request.

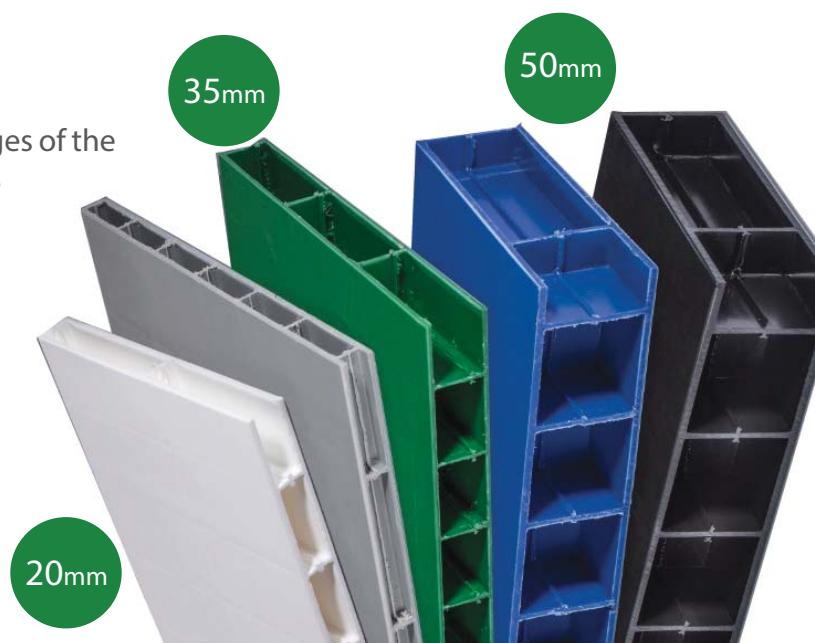

PANELTIM® LIGHTWEIGHT PANEL 50MM



◆ **Material:** PP COPO

◆ **Wall thickness:** 3.5mm

◆ **Internal structure:** 50/100mm

◆ **Dimensions**

- 1200 x 800 x 50mm*

- 1200 x 1000 x 50mm*

- 2600 x 1000 x 50mm

*Customized dimensions available
Always with internal double cross

◆ **Weight:** ±10kg/m²

◆ **Packaging:** 30 pcs/pallet

◆ **Surface:** smooth

◆ **Temperature:** -20°C / +80°C



The 50mm lightweight panel with 50/100mm internal cell structure is highly suitable for dividers, stable doors, non-supporting walls, personnel doors, etc. In short any application which requires a light, strong and hygienic solution. The panel has a thick wall but is nevertheless light and rigid.

The panel's thinness and light weight positively affects total cost price of the application. If required, we can offer a total modular system with a complete range of assembly profiles.

Stable doors, windows and door systems with flexible measures are also available.

Because the panels are easy to install, a lot of time can be saved as wires, cables and operating systems can be attached directly to the walls (ideal for corridors).

Paneltim® panels never require any maintenance once they are fitted.

Colour combinations or combinations with Venti® panels are possible on demand.



PANELTIM® LIGHTWEIGHT PANEL 35MM



◆ **Material:** PP COPO

◆ **Wall thickness:** 3.5mm

◆ **Internal structure:** 50/100mm

◆ **Dimensions:**

- 1200 x 800 x 35mm

- 1200 x 1000 x 35mm

Customized dimensions available
Always with internal double cross



◆ **Weight:** ±8.75 kg/m²

◆ **Packaging:** 30 pcs/pallet

◆ **Surface:** smooth



◆ **Temperature:** -20°C / +80°C



The 35mm lightweight panel with 50/100mm internal cell structure is highly suitable for the housing of calves, pigs, sheep, goats, poultry, rabbits, cats and dogs, guinea pigs, birds and other pets. The panel is also perfect to create lids, partitions, shelves, cupboards, tables and benches for the vegetable and fruit sector, etc. In brief, any application which requires a light and hygienic solution.

Stable door systems with flexible measures are also available. Paneltim® panels never require any maintenance once they are fitted. Colour combinations are possible on demand.

These hygienic plastic panels preserve all advantages of the 50mm panels, but they are lighter and thinner, thus saving space. Though they are thinner, they have surprising characteristics on stiffness and bending.



PANELTIM® LIGHTWEIGHT PANEL 20MM



- ◆ **Material:** PP COPO
- ◆ **Wall thickness:** 3.5mm
- ◆ **Internal structure:** 50/100mm



- ◆ **Dimensions:**
 - 1200 x 800 x 20mm
 - 1200 x 1000 x 20mm

Customized dimensions available
Always with internal double cross



- ◆ **Weight:** ±7.5 kg/m²
- ◆ **Packaging:** 50 pcs/pallet

- ◆ **Surface:** smooth



- ◆ **Temperature:** -20°C / +80°C

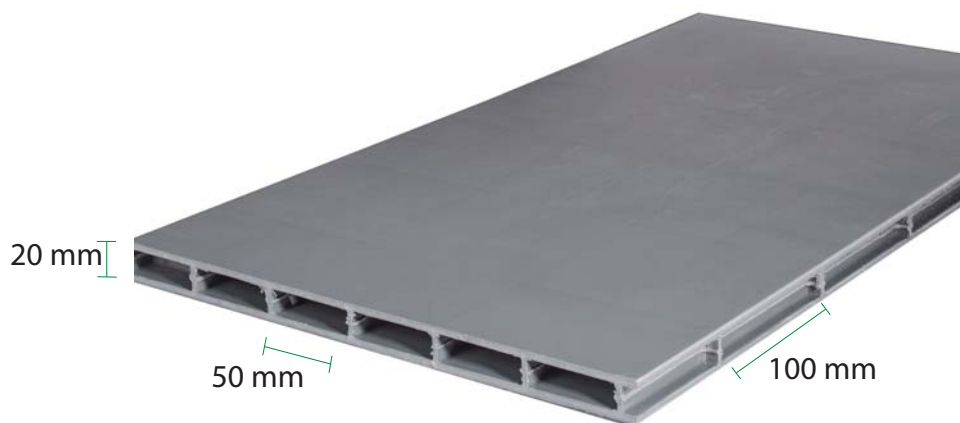

The 20mm lightweight panel with 50/100mm internal cell structure is highly suitable for the housing of calves, pigs, sheep, goats, poultry, rabbits, cats and dogs, guinea pigs, birds and other pets. The panel is also perfect to create lids, partitions, shelves, cupboards, tables and benches for the vegetable and fruit sector, etc. In brief, any application which requires a light and hygienic solution.

Stable door systems with flexible measures are also available. Paneltim® panels never require any maintenance once they are fitted. Colour combinations are possible on demand.

These hygienic plastic panels preserve all advantages of the 50mm panels, but they are lighter and thinner, thus saving space. Though they are thinner, they have surprising characteristics on stiffness and bending.



PANELTIM® VENTI 30® PANEL 50MM

Patent 98201105.8-2313



◆ **Material:** PP COPO

◆ **Wall thickness:** 3.5mm

◆ **Openings:** 30 x 350mm

◆ **Dimensions:**

- 1200 x 800 x 50mm

- 1200 x 1000 x 50mm

Customized dimensions available



◆ **Weight:** ±11 kg/m²

◆ **Packaging:** 20 pcs/pallet

◆ **Surface:** smooth



◆ **Temperature:** -20°C / +80°C

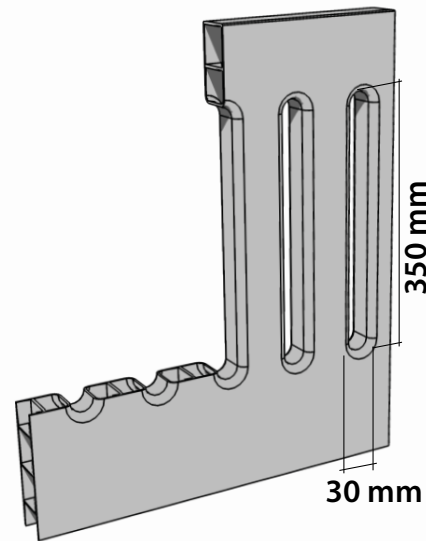

The Paneltim® Venti® panel has a row of vertical openings every 100mm (30mm wide and 350mm high).

Using Venti® panels reduces stress by diminishing claustrofobic effects. As the narrow openings start halfway up the panel, the animals have little or no physical contact. Furthermore, The animals benefit from the increased air circulation through the openings in the dividers and the pen fronts.

The effect of a partially slatted floor, can be reproduced in these divisions by having part solid and part ventilated panels, all manufactured in one piece. This makes it is possible to influence manure behaviour.

Venti® panels can be made in any size (f.i. variable heights) by butt welding. The number of openings can be reduced to an absolute minimum by customising the panel.



PANELTIM® ANTISKID PANELS 50MM



◆ **Material:** PP COPO

◆ **Wall thickness:** 3,5mm

◆ **Internal structure:** 50/50mm

◆ **Dimensions:**

- 1200 x 1000 x 50mm

Customized dimensions available



◆ **Weight:** ±12 kg/m²

◆ **Packaging:** 20 pcs/pallet

◆ **Surface:** antiskid studs with 2 and 2.5mm intervals



◆ **Temperature:** -20°C / +80°C

◆ **Antiskid structure:**

- Checkerplate
- Studs

Distance of antiskid structure to edge: 40mm

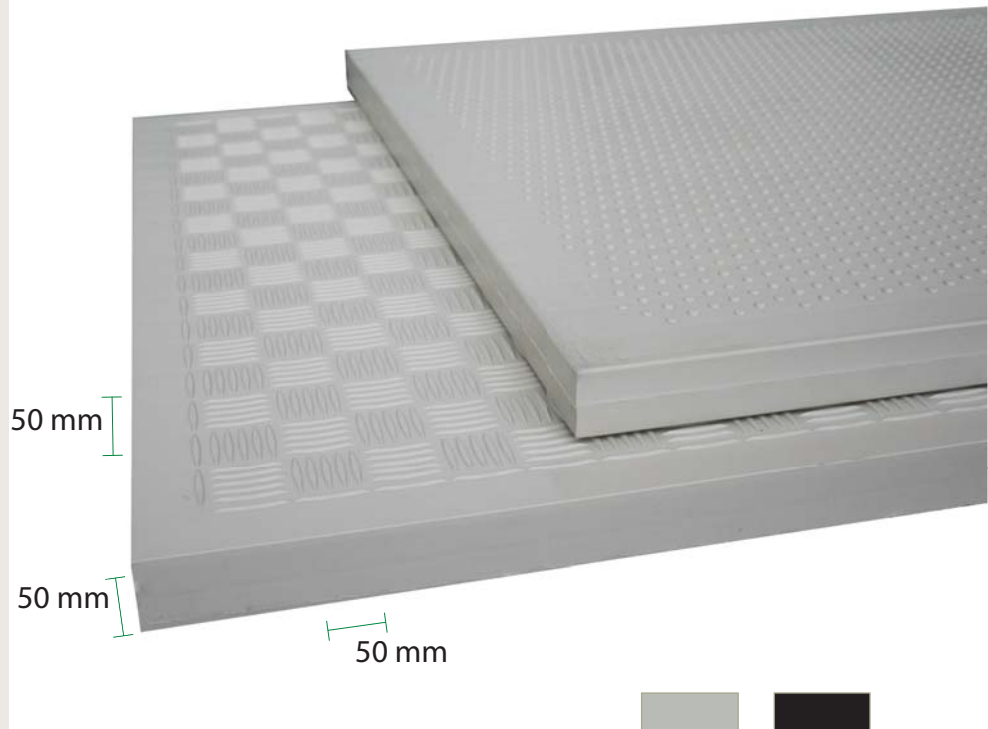

Paneltim®'s panel range includes two varieties of antiskid panels with a reinforced 50x50mm internal cell structure: a checkerplate and stud antiskid structure. Both types of panel are light, rigid and closed on all sides which makes them easy to clean.

Tests revealed that both antiskid panels have a high skid resistance. Both in wet and dry condition, they meet the requirements of the Dutch certification system for sustainable livestock (skid resistance of minimum 0.60 when measured according to the FSC-2000 method). Having a high skid resistance, they are perfectly fit for floors in hallways, stairs and covers. Just like the other panels in Paneltim®'s product range, they can be customized for any size.



PANELTIM® PLUS SLAT IN



◆ **Material** : PP Copo

◆ **Height:**

50mm, 15mm above the supports

◆ **Dimensions :**

PLUS open slat

- 200 x 400 mm
- 300 x 400 mm
- 600 x 400 mm
- 300 x 600 mm
- 200 x 500 mm
- 600 x 500 mm

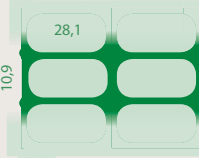

PLUS closed slat

- 200 x 400 mm
- 200 x 500 mm
- 800 x 500 mm

Edge seal strip: 200 mm



◆ **Weight** : 7 kg/m²

◆ **Colour** : Orange, RAL2009

◆ **Supports :**

- 60/30/5 mm: tot 1200 mm
- 85/30/5 mm: tot 1700 mm
- 100/30/5 mm: tot 2000 mm
- 120/30/5 mm: tot 2400 mm

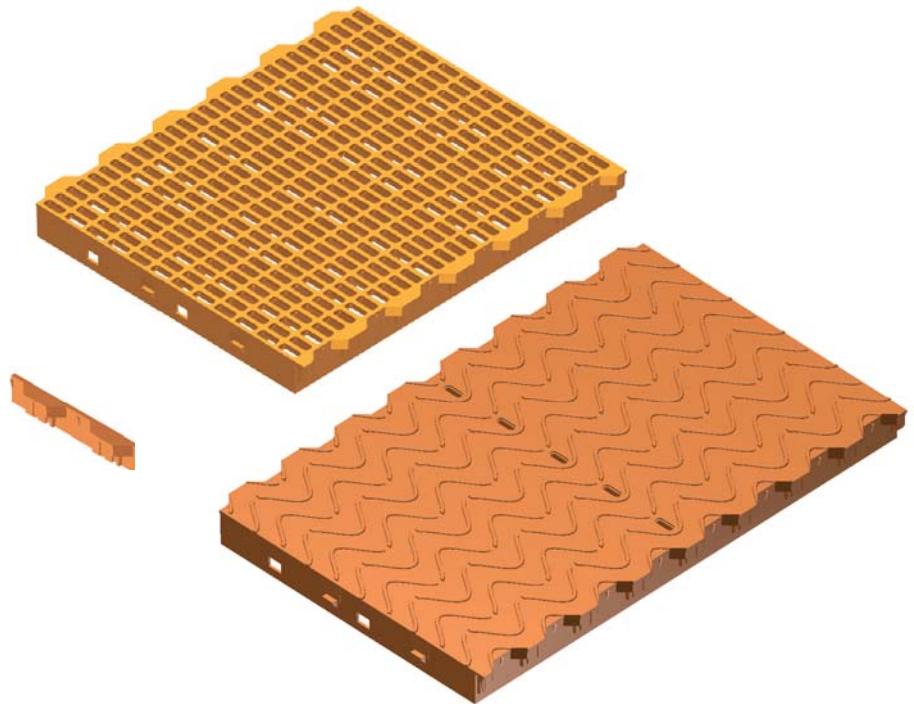

Paneltim® Plus slats are resistant to almost all chemical substances, moulds, bacteria and disinfectants. They are corrosion-proof and have a high resistance against dynamic shock. The slats are very rigid, 100% recyclable and ensure total hygiene thanks to their rounded design and their excellent manure permeability (60%). Furthermore, the mushroom-shaped finish of the ribs gives piglets a good grip and prevents their toes from getting stuck between the openings.

Paneltim® Plus slats have an ingenious self-anchorage hook system, allowing an easy modular installation.

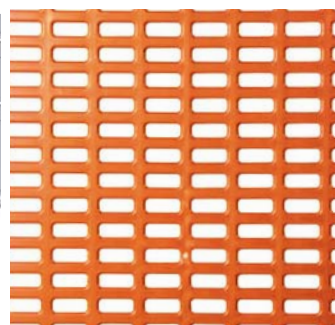
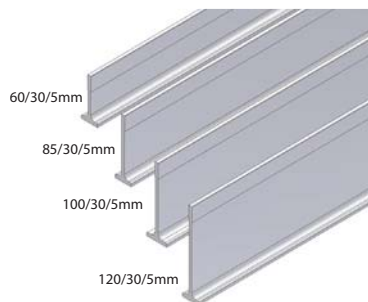

PANELTIM® DELTA SENIOR SLAT



◆ **Material** : PP Copo

PP

◆ **Plastic height:**

25mm



◆ **Dimensions :**

- 1200 x 400 mm

- 1500 x 400 mm

- 1600 x 400 mm



◆ **Weight** : 12,25 kg/m²

◆ **Colour** : green

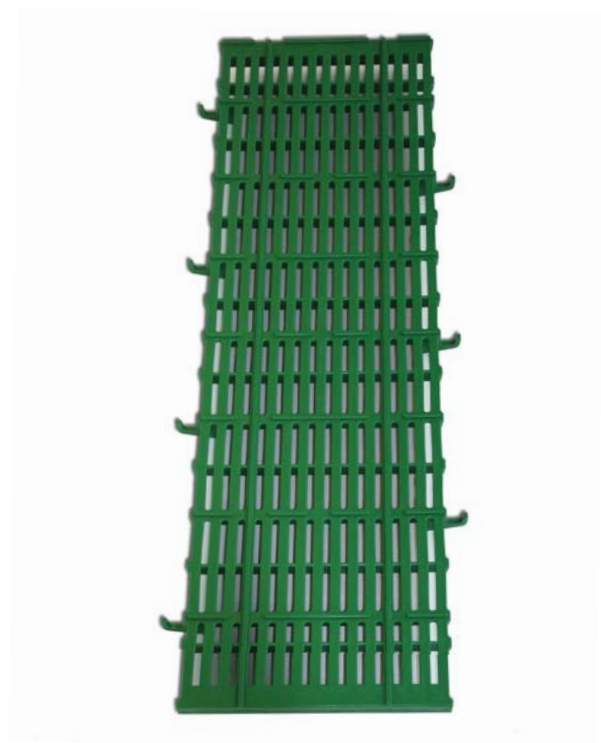

The Paneltim® Delta Senior slat is made out of polypropylene and is resistant to wear and aging. The slat is shock and corrosion proof, ecological and 100% recyclable. It is completely resistant to most chemical substances, moulds, bacteria and disinfectants.

The slat has a highly permeable surface structure and functional anti-skid profile without sharp or cutting edges. The structure prevents calves from skidding and is virtually self-cleansing. It is also the ideal base for straw.

The Paneltim® Delta Senior slats are easy to fit and are connected along the side via a functional hinging hook system. This slat is an economically responsible alternative to a wooden slat.

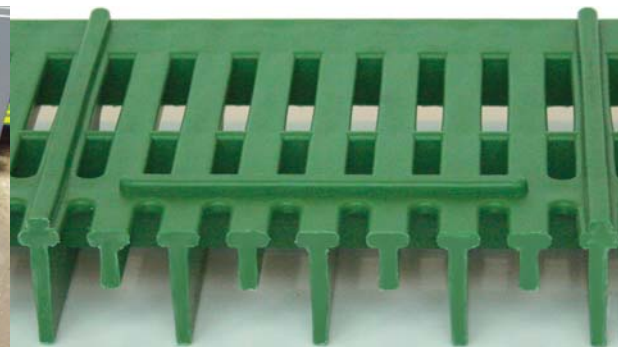

SHOWCASE



PANELTIM® SERVICE

Supplied according to plan

- ◆ Paneltim® can provide a detailed proposal with drawings. Upon order, a 3D assembly drawing can be made with a detailed part list.

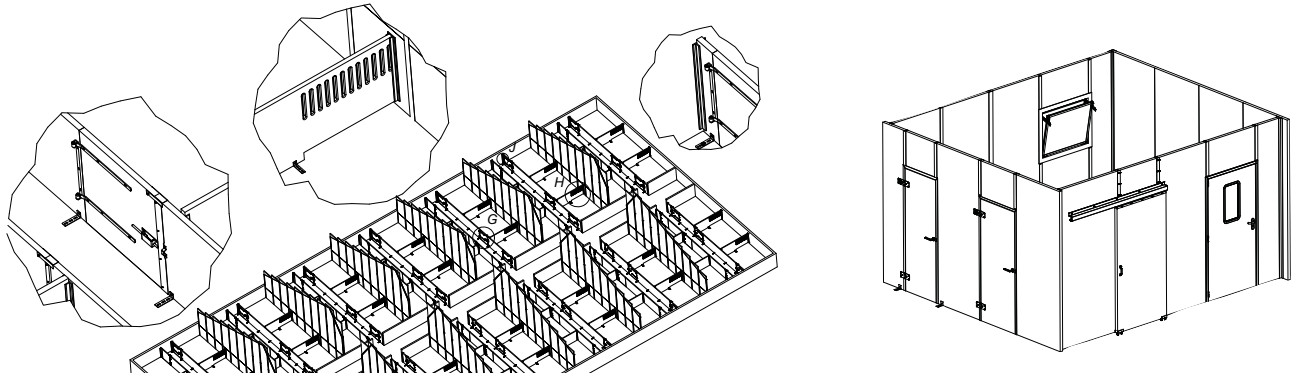

- ◆ According to the drawing, the panels are welded together in our workshop. This enables construction with a minimum quantity of assembly parts.
- ◆ Upon request, CNC-milled panels can be provided in order to reduce on-site assembly time.
- ◆ Paneltim® offers a wide range of assembly parts such as profiles in PVC, composite or stainless steel or tailor-made pieces according to your design. If needed, we can provide a complete assembly package.

Short delivery times

Paneltim® has a large stock at its disposal and has enough production capacity to ensure short delivery terms.

Flexible and solution-minded

Non-standard colours are available on request, with a minimum order quantity. Furthermore, we can assist you in finding the right solution for your needs.

Transport volume

Paneltim® panels are light and stackable, which keeps large distance transport costs affordable. Logistical services are available upon request, with an optimal use of transport volumes.

Quality

Our daily challenge is to innovate, in order to optimise quality and to search for product possibilities in cooperation with our customers.



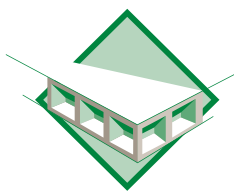

PANELTIM[®]

Pioneer in plastic sandwich panels

PANELTIM[®] nv
Industrielaan 38 | B-8810 Lichtervelde | Belgium
Tel. +32 (0)51 72 67 60 | Fax +32 (0)51 72 49 43
paneltim@paneltim.com | WWW.PANELTIM.COM

