

Farrow 1 13:21  
Mode: Normal SP: 99.0  
Temp: 100.3°F H: 101.4  
Output: 30% L: 98.2



Press and hold to  
reset growth curve

Press  
and hold

- Growth curve ●
- Output ●
- Alarm ●



IHT Innovative Heating  
Technologies

HH-HMC-2

Copyright Phason Inc.  
All rights reserved.  
34144000-IHT

# Table of contents

Chapter 1: Introducing the Hog Hearth Heat Mat Control .....	5
Introducing the HMC-2 .....	5
Features .....	5
Electrical ratings .....	5
Becoming familiar with the Heat Mat Control.....	6
Menus and displays.....	7
Chapter 2: Installing your Heat Mat Control .....	8
What you need to know before installing .....	8
Mounting your control .....	8
Heat Mat Control layout.....	9
Connecting equipment .....	10
Connecting heat mats .....	10
Connecting an alarm system.....	12
Finishing the installation .....	13
Chapter 3: Configuring and programming .....	14
Configuring control functions .....	14
Entering a name .....	14
Selecting the temperature probe type.....	15
Setting the probe correction value .....	16
Selecting the temperature units.....	16
Setting the time.....	17
Changing the operating frequency.....	17
Programming control operation .....	18
Programming the set point.....	18
Programming the growth curve.....	18
Programming alarm settings .....	21
Chapter 4: Monitoring and maintaining your HMC-2 .....	23
Monitoring your Heat Mat Control .....	23
Acknowledging alarms .....	23
Servicing and maintaining your control.....	24
Using manual override mode .....	24
Saving and restoring settings .....	25
Displaying the version .....	26
Restoring the factory defaults.....	27
Updating the firmware .....	27
Optional accessories and kits .....	29
Appendices .....	30
Appendix A: Troubleshooting.....	30
Alarm and error messages .....	30
Troubleshooting.....	31
Appendix B: Factory defaults and worksheet .....	31
Appendix C: Surge suppression and electrical noise .....	33
Understanding power surges and surge suppression.....	33
Reducing electrical noise using filters .....	33
Index .....	34



---

## ***Chapter 1: Introducing the Hog Hearth Heat Mat Control***

### **Introducing the HMC-2**

The Hog Hearth Heat Mat Control is an automatic temperature-based control with a 20 amp variable stage for controlling heat mats.

The Heat Mat Control is loaded with powerful features, including a six-step growth curve. All control functions are never more than a few button presses away, making the HMC-2 one of the easiest controls to program.

The Heat Mat Control displays temperature, mode, alarm, and status information. Monitoring the control regularly gives you a better idea of what is going on with your equipment and in your facility.

### **Features**

- ◆ Automatic temperature-based control, range: 70 to 125°F (21 to 51.7°C)
- ◆ Six-step growth curve, up to 365 days duration
- ◆ One variable heating stage for controlling heat mats
- ◆ One alarm relay for external alarm system or siren
- ◆ Large 20-character, 4-line LCD display
- ◆ Minimum and maximum temperature logging
- ◆ Alarm message display
- ◆ Manual override mode
- ◆ Power-failure settings protection
- ◆ Temperature probe input
- ◆ Rugged enclosure (corrosion resistant, water resistant, and fire retardant)
- ◆ CSA approval
- ◆ Limited warranty (two years)

### **Electrical ratings**

- ◆ Input power: 120/230 VAC, 50/60 Hz
- ◆ Input fuse: 250 V, 1 A fast-acting glass
- ◆ Variable AC: 20 A at 120/230 VAC, general-purpose (resistive)  
2300 W at 120 VAC; 4600 W at 230 VAC
- ◆ Alarm relay: 0.4 A at 125 VAC; 2 A at 30 VDC, resistive load  
0.2 A at 125 VAC; 1 A at 30 VDC, inductive load

## Becoming familiar with the Heat Mat Control

The four-line LCD display shows temperatures, alarm messages, and programming information.

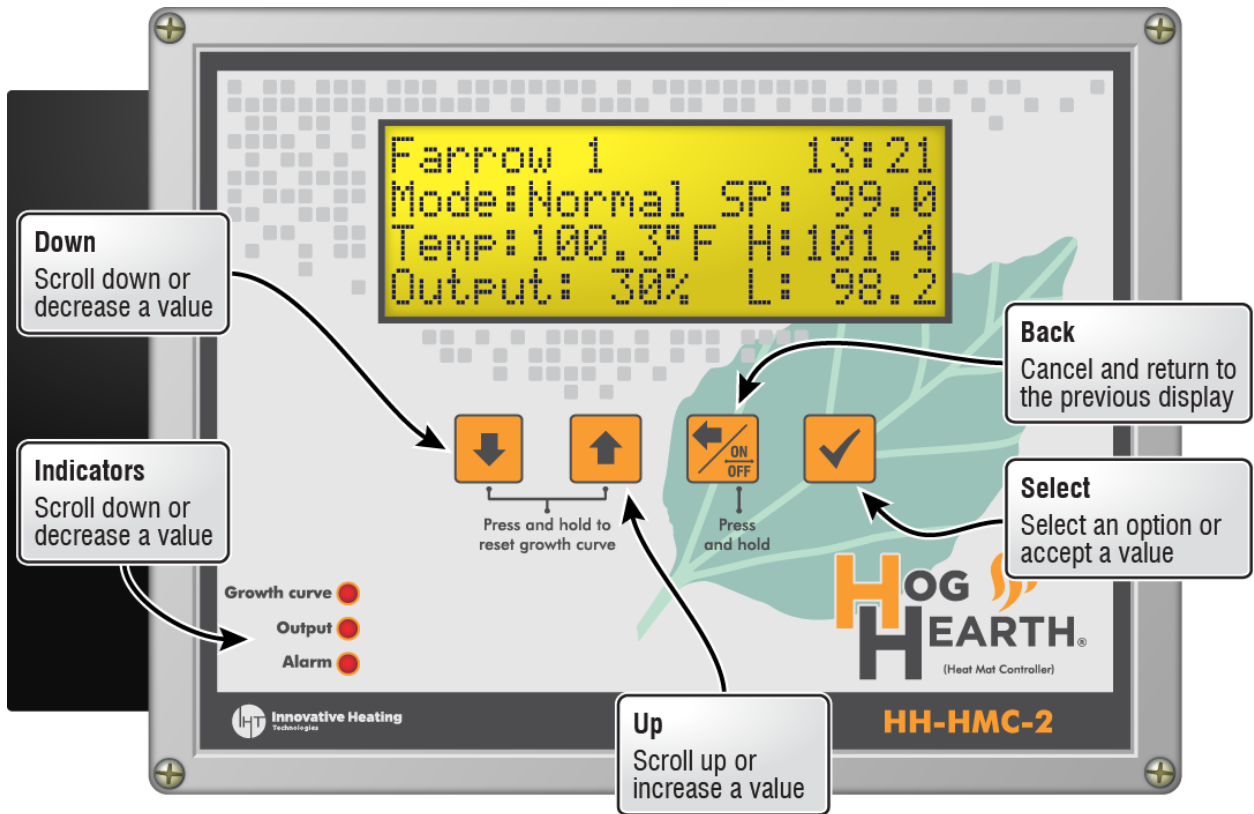

### NOTE

If you leave Heat Mat Control in a menu or display other than the main display, the control returns to the main display after five minutes without any key presses. The only exception is manual override mode; the control remains in override mode until you manually exit.

## Menus and displays

### Main display

- ◇ Shows status
- ◇ Press **Select** to go to the main menu.

```
Farrow 1 13:21
Mode:Normal SP: 99.0
Temp:100.3°F H:101.4
Output: 30% L: 98.2
```

### Main menu

Provides access to all configuration, settings, and functions.

- ◇ Press **Up** or **Down** to move through the menu.
- ◇ Press **Back** to return to the previous screen.
- ◇ Press **Select** to access an item.

```
MAIN MENU
1 Manual Override
2 Program Settings
3 Configuration
4 About
```

### Program settings menu

For more information, read:

- ◇ **Programming the set point** on page 18
- ◇ **Programming the growth curve** on page 18
- ◇ **Programming alarm settings** on page 21

```
PROGRAM SETTINGS
1 Set Point
2 Growth Curve
3 Alarms
```

### Configuration menu

Provides access to configuration and maintenance items.

For more information, read:

- ◇ **Entering a name** on page 14
- ◇ **Selecting the temperature probe type** on page 15
- ◇ **Setting the probe correction value** on page 16
- ◇ **Selecting the temperature units** on page 16
- ◇ **Setting the time** on page 17
- ◇ **Changing the operating frequency** on page 17
- ◇ **Saving and restoring settings** on page 25
- ◇ **Updating the firmware** on page 27
- ◇ **Restoring the factory defaults** on page 27

```
CONFIGURATION
1 Room Name
2 Probe
3 Time
4 Frequency
5 Save Settings
6 Restore Settings
7 Factory Defaults
8 Update Firmware
```

### About display

Shows the version and date of the firmware.

```
Heat Mat Control
Version U#.##
      ##/##/####
```

---

## Chapter 2: Installing your Heat Mat Control

- ◆ **What you need to know before installing** below
- ◆ **Connecting equipment** on page 10
- ◆ **Finishing the installation** on page 13

### What you need to know before installing

Before installing, you need to do some initial preparation:

1. Read the **Control Fundamentals** guide that came in the box with your control.
2. Read **Understanding power surges and surge suppression** on page 33.



- ◇ If you do not install external surge suppression devices, you risk damage to the electronics inside your Heat Mat Control, which might cause your control to fail.
- ◇ Because it is not possible to completely protect this product internally from the effects of power surges and other transients, we *highly recommend* that you install external surge suppression devices. For specific recommendations, see your electrical contractor.
- ◇ If you do not take these precautions, you acknowledge your willingness to accept the risk of loss or injury.

### Mounting your control

1. Select a location for your control. Make sure you have enough cable and wire to reach all the equipment you want to control.
2. Remove the screws from the front cover and then gently lift it off.
3. Mount the enclosure to a wall using the four screws provided with the control. Insert the screws into the large holes in each corner of the box and then tighten.

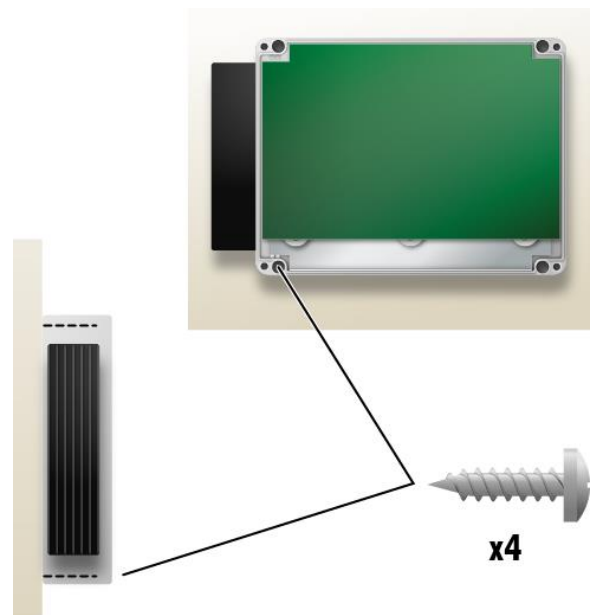



## Heat Mat Control layout

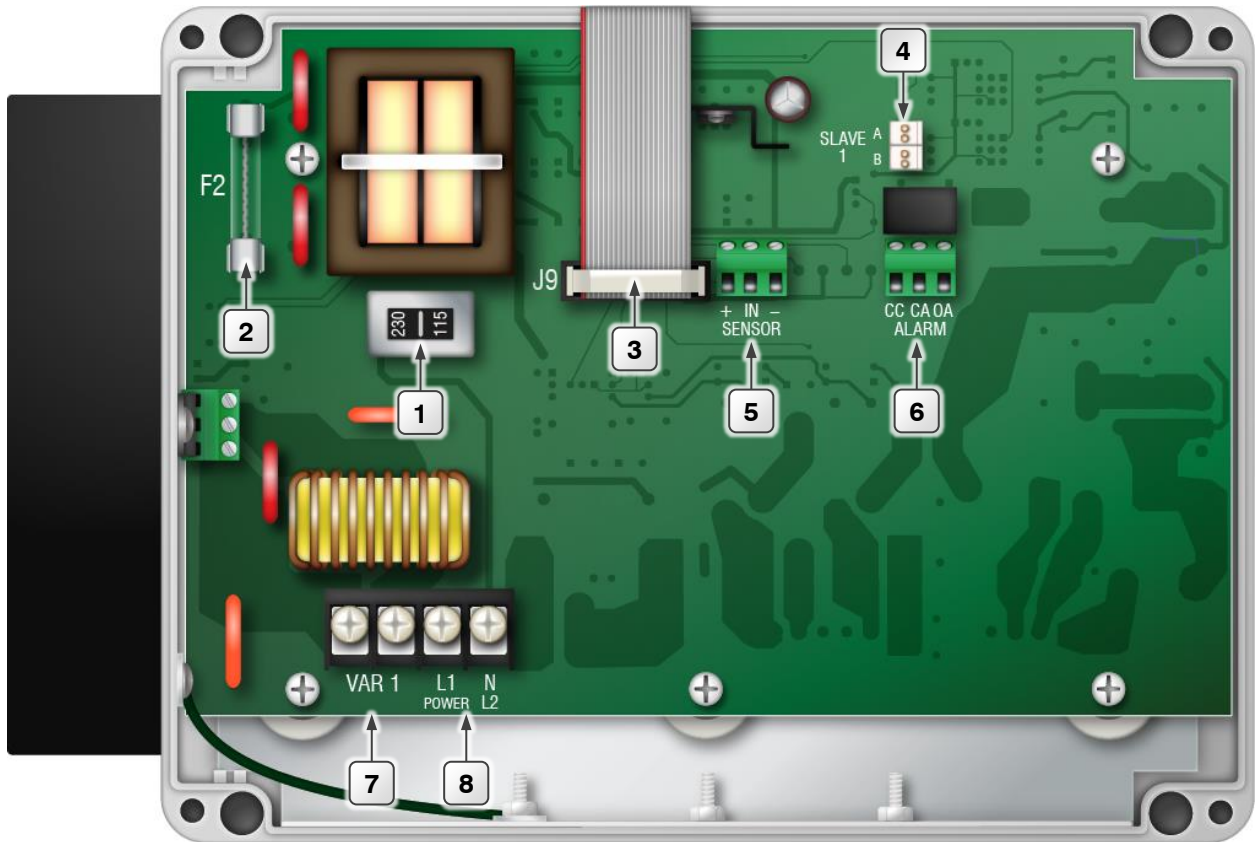

- 1 **Voltage selection switch:** set this switch to the correct line voltage before installing the HMC-2.
- 2 **Control fuse:** 250 V, 1 A fast-acting glass.
- 3 **Display cable:** make sure the ribbon cable from the display is properly connected to the socket.
- 4 **Heat Mat Controller Slave connection:** if you are using slave units to expand the capacity of your control system, connect them here. For more information, read the **Heat Mat Controller Slave installation guide**.
- 5 **Temperature probe terminals:** connect the temperature probe to the **IN** and **-** of this terminal.
- 6 **Alarm relay terminals:** connect an external alarm system or alarm siren to this terminal.
- 7 **Variable AC terminals:** connect heat mats to these terminals.
- 8 **Incoming power terminals:** connect the incoming power (120/230 VAC, 50/60 Hz) to this terminal.

## Connecting equipment



- ◇ Before connecting the incoming power, switch OFF the power at the source.
- ◇ Do not switch ON the power until you have finished all wiring and verified all equipment is properly connected and free of obstructions.



Use the electrical knockouts for bringing wires or cables into or out of your control enclosure. Do not make additional holes in the enclosure; this can damage the watertight seal or control components and void the warranty.

## Connecting heat mats

To control heat mats, you need to connect the following to the Heat Mat Control.

- ◆ Incoming power (120/230 VAC, 50/60 Hz)
- ◆ Heat mat
- ◆ Temperature probe



You can connect more than one heat mat to the variable stage as long as the total current draw does not exceed the stage's limit.

**Variable stage ratings:** 20 A at 120/230 VAC, general-purpose (resistive)  
2300 W at 120 VAC; 4600 W at 230 VAC

## Temperature probe information

The HMC-2 is compatible with heat mats that have an internal temperature probe (must be 1K  $\Omega$  at 25°C), such as the Hog Hearth® heat mat.

## Temperature probe installation guidelines

- ◆ Do not run the probe cable in the same conduit as AC power cables
- ◆ Do not run the sensor cable beside AC power cables or near electrical equipment.
- ◆ When crossing other cables or power lines, cross them at a 90-degree angle.



Replace damaged probes as soon as possible. If there is no probe present or working properly, the control uses the set point as the current temperature.

**To connect heat mats**

1. Set the voltage selection switch to the correct line voltage.
2. Connect the incoming power and heat mat as shown in the diagram.
3. Connect the temperature probe as shown in the diagram.

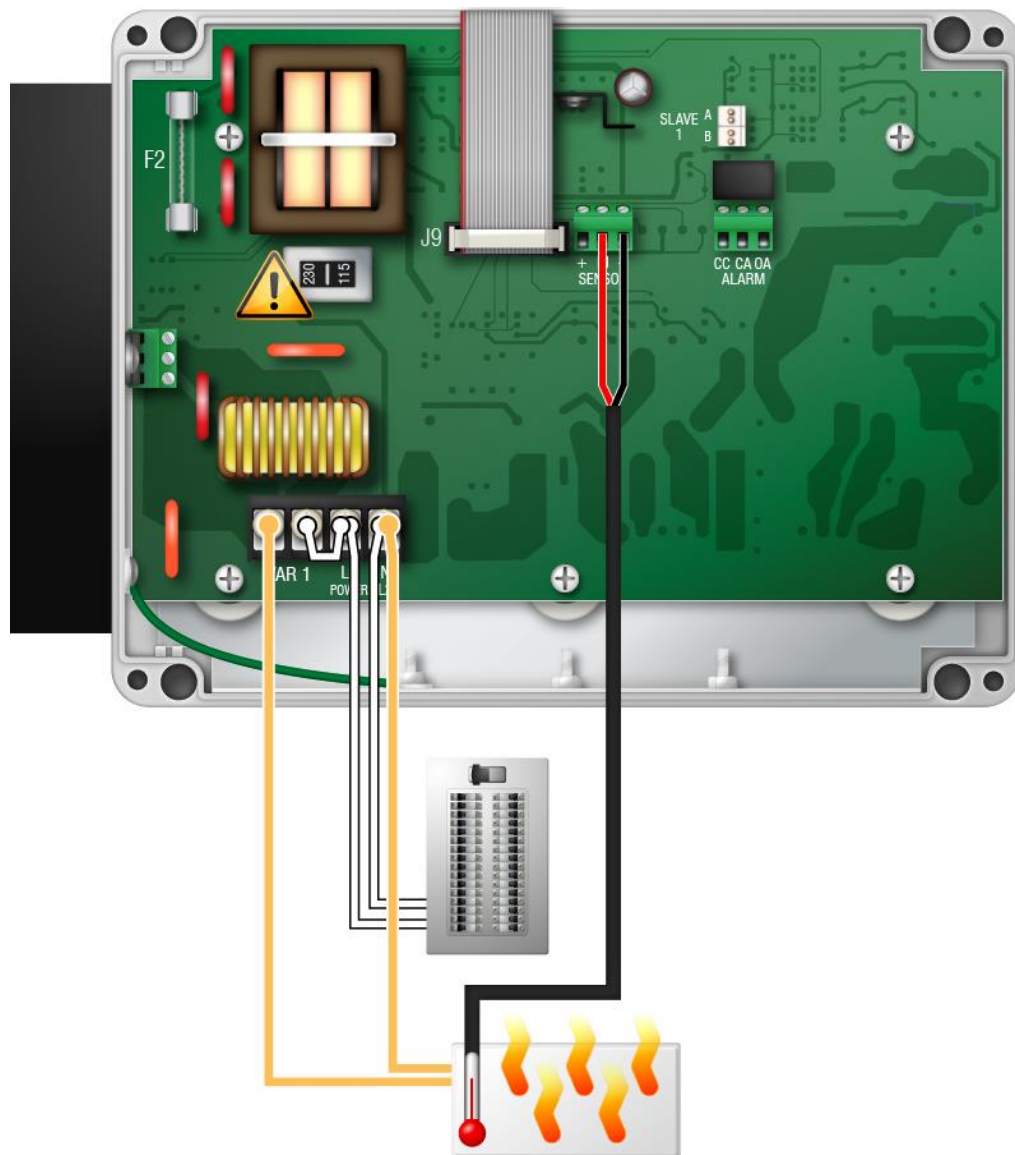

## Connecting an alarm system

You can connect an alarm system to your Heat Mat Control. An alarm system can be a siren, alarm panel, or auto-dialer. Read your alarm system's installation guide for installation instructions and information about the type of system: **normally open** or **normally closed**.

Below are the descriptions for the alarm terminal.

- ◆ **CC:** common connection
- ◆ **CA:** normally open; closes during alarm conditions
- ◆ **OA:** normally closed; opens during alarm conditions

For the alarm system to sound (or dial out) during an alarm condition, you must enable the alarms. For more information, read **Programming alarm settings** on page 21.



The ratings of the alarm system must not exceed the ratings of the relay.

**Alarm relay ratings:** 0.4 A at 125 VAC; 2 A at 30 VDC, resistive load  
0.2 A at 125 VAC; 1 A at 30 VDC, inductive load

### To connect an alarm system

- ◆ If you are connecting the alarm system to a network of controls and your system uses a **normally open** connection (closes on alarm), connect the system as shown in the normally open diagram.

Join all the common (CC) connections together and all the closed-on-alarm (CA) connections together. The alarm relays must be **in parallel** with each other so any control can trigger the alarm system when an alarm condition occurs.

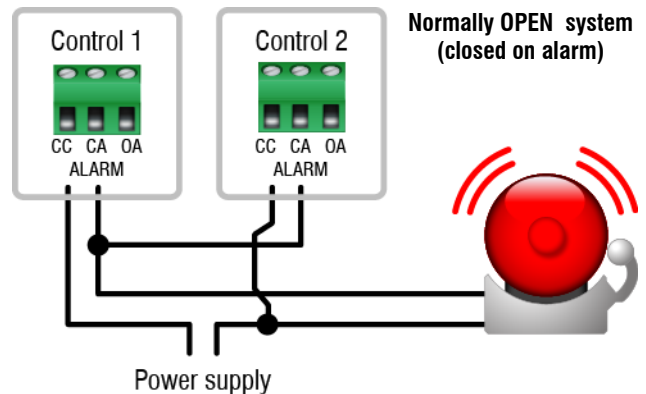

- ◆ If you are connecting the alarm system to a network of controls and your system uses a **normally closed** connection (opens on alarm), connect the system as shown in the normally closed diagram.

Join the alarm relays in a continuous loop. The alarm relays must be **in series** with each other so any control can trigger the alarm system when an alarm condition occurs.

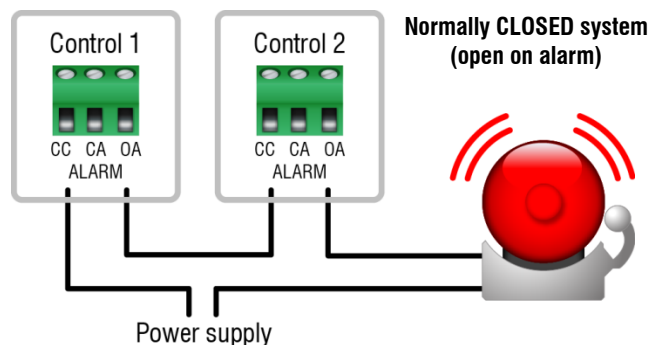

## Finishing the installation

1. Make sure all wires are properly connected to the correct terminals.
2. Make sure the display cable is properly connected. For more information, read **Heat Mat Control layout** on page 9.
3. Place the cover on the control and then tighten the screws a few turns.
4. Switch on the power.  
As soon as the power comes on, you should see the power fail message. If the display does not come on, check the ribbon cable to make sure it is properly connected.

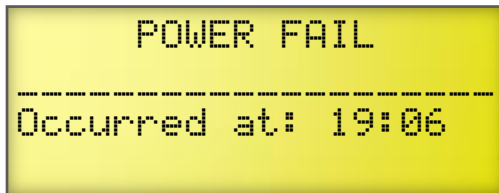

5. Press **Select** until you see the main display.

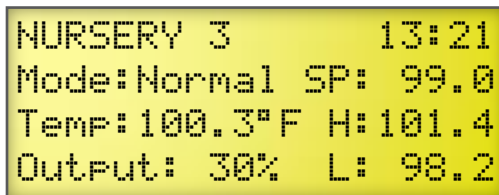

6. Test the installation and equipment using manual override. For more information, read **Using manual override mode** on page 24.
7. When finished, tighten the four cover screws.



Do not over tighten the screws. Avoid using power screwdrivers or drills.

---

## Chapter 3: Configuring and programming

- ◆ **Configuring control functions** below
- ◆ **Programming control operation** on page 18

### Configuring control functions

Control functions are parameters you change very rarely or not at all. Control functions include:

- ◆ Room name (below)
- ◆ Temperature probe:
  - ◆ Type (on page 16)
  - ◆ Units (on page 16)
  - ◆ Correction (on page 16)
- ◆ Time (on page 17)
- ◆ Frequency (on page 17)



- ◇ Before you configure your control, make sure it has power and all equipment is properly connected.
- ◇ If you receive an error message during configuration, look it up in **Appendix A: Troubleshooting** on page 30 and then follow the instructions for correcting the problem.

### Entering a name

If you want, you can enter a name or description for the control. The name displays in the top left corner of the main display.

```
NURSERY 3 ← 13:21
Mode:Normal SP: 99.0
Temp:100.3°F H:101.4
Output: 30% L: 98.2
```

**To enter a name**

1. In the Configuration menu, press **Down** until the cursor is beside **Room Name**, and then press **Select**.
2. Press **Select**.
3. Press **Up** or **Down** to scroll through the list of characters. When the one you want is shown, press **Select**.
4. Repeat step 3 until you have entered your information.
5. Press **Back** until you reach the menu you want.

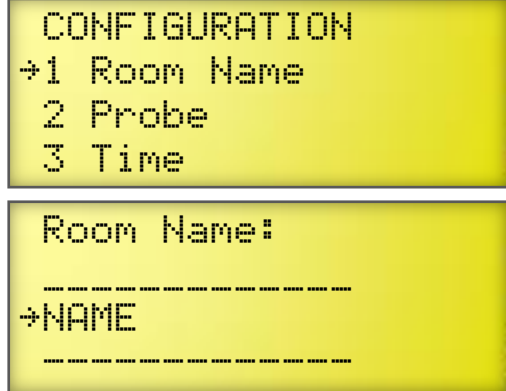
**Selecting the temperature probe type**

The HMC-2 is compatible with heat mats that have an internal temperature probe (must be 1K  $\Omega$  at 25°C), such as the Hog Hearth® heat mat.

External 3K and 5K probes are available that are specifically designed to work with heat mats. For more information, contact your dealer.

*Default:* 1K  $\Omega$  (type B)

*Options:* 3K (type A), 5K (type C)

**To select the probe type**

1. In the Configuration menu, press **Down** until the cursor is beside **Probe**, and then press **Select**.
2. Press **Down** until the cursor is beside **Type**, and then press **Select**.
3. Press **Select**.
4. Press **Up** or **Down** to change the configuration, and then press **Select**.
5. Press **Back** until you reach the menu you want.

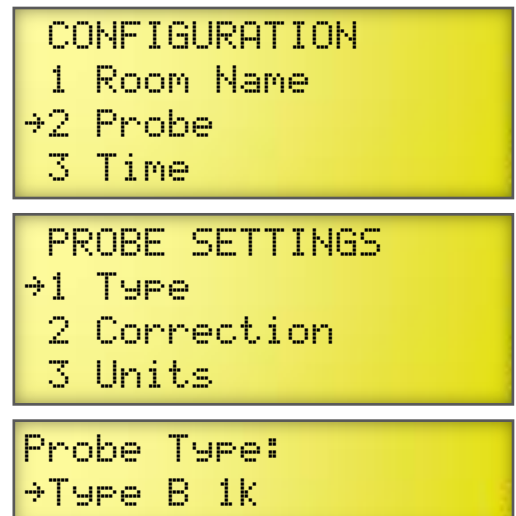

## Setting the probe correction value

Probe correction allows you to adjust the temperature measured by the Heat Mat Control when using an external heat mat probe. You might want to use probe correction if the temperature measured is higher or lower than the temperature of the mat surface.

The probe correction value is an offset from the measured temperature. A negative value subtracts from the measured temperature, a positive value adds to it. For example, if the measured temperature is 70°F and the correction value is 2.5°F, the control will use and display 72.5°F.

*Default:* -6.0°F (-3.3°C)

*Range:* -9.0 to 9.0°F (-5.0 to 5.0°C)

### To set the probe correction value

1. In the Configuration menu, press **Down** until the cursor is beside **Probe**, and then press **Select**.
2. Press **Down** until the cursor is beside **Correction**, and then press **Select**.
3. Press **Select**.
4. Press **Up** or **Down** to change the configuration, and then press **Select**.
5. Press **Back** once to return to the Configuration menu, or twice to return to the Main menu.

```
CONFIGURATION
1 Room Name
→2 Probe
3 Time
```

```
PROBE SETTINGS
1 Type
→2 Correction
3 Units
```

```
Probe Correction:
→-2.5°F
```

## Selecting the temperature units

Your Heat Mat Control can display temperatures in either degrees Fahrenheit (°F) or degrees Celsius (°C), but not both at the same time.

*Default:* Fahrenheit

1. In the Configuration menu, press **Down** until the cursor is beside **Probe**, and then press **Select**.
2. Press **Down** until the cursor is beside **Units**, and then press **Select**.
3. Press **Select**.
4. Press **Up** or **Down** to change the configuration, and then press **Select**.
5. Press **Back** once to return to the Configuration menu, or twice to return to the Main menu.

```
CONFIGURATION
1 Room Name
→2 Probe
3 Time
```

```
PROBE SETTINGS
1 Type
2 Correction
→3 Units
```

```
Probe Unit:
→°F
```



## Setting the time

Your Heat Mat Control has a 24-hour clock. The control uses the clock to calculate settings for the growth curve function.

### To set the time

1. In the Configuration menu, press **Down** until the cursor is beside **Time**, and then press **Select**.
2. Press **Select**.
3. To adjust the hours, press **Up** or **Down**, and then press **Select**.
4. To adjust the minutes, press **Up** or **Down**, and then press **Select**.
5. Press **Back** once to return to the Configuration menu, or twice to return to the Main menu.

```
CONFIGURATION
1 Room Name
2 Probe
→3 Time
```

```
→Time: 16:44 hh:mm
```

## Changing the operating frequency

In North America, utility companies supply power at 60 Hz. In some areas of the world, such as Europe, power is supplied at 50 Hz.

*Default: 60 Hz*

### To change the operating frequency

1. In the Configuration menu, press **Down** until the cursor is beside **Frequency**, and then press **Select**.
2. Press **Select**.
3. Press **Up** or **Down** to switch between 50 and 60 Hz, and then press **Select**.
4. Press **Back** once to return to the Configuration menu, or twice to return to the Main menu.

```
1 Room Name
2 Probe
3 Time
→4 Frequency
```

```
→Frequency: 60 Hz
```

## Programming control operation

Programming your Heat Mat Control means telling it what you want the equipment to do and when you want it done. For example, you might say “I want the temperature to remain at 99°F”, or “I want to be alerted when the temperature drops below 95°F.”



Use **Appendix B: Factory defaults and worksheet** on page 31 when programming your Heat Mat Control.

### Programming the set point

The Heat Mat Control continually monitors temperature and adjusts output to maintain the set point.

*Default:* 99.0°F (37.2°C)

*Range:* -13 to 125°F (-25 to 51.7°C)

#### To program the set point

1. In the Program Settings menu, with the cursor is beside **Set Point**, press **Select**.
2. Press **Select**.
3. Press **Up** or **Down** to adjust the setting, and then press **Select**.
4. Press **Back** once to return to the Program Settings menu, or twice to return to the Main menu.

```
PROGRAM SETTINGS
→1 Set Point
  2 Growth Curve
  3 Alarms
```

```
→Set Point: 99.0°F
```



If the growth curve is enabled, the Heat Mat Control will automatically adjust the set points over time. For more information, read **Programming the growth curve** below.

### Programming the growth curve

The growth curve automatically adjusts temperature set point over time, up to a maximum of 365 days.

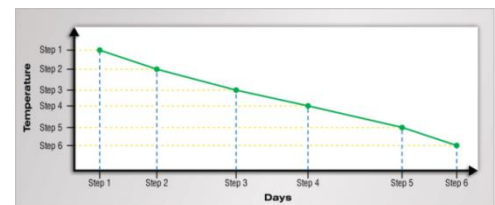

There are 6 steps in the growth curve; each step has a start day and a temperature. The control calculates the set point for each day between the steps, and then adjusts it each day at midnight.

**Example**

Step 2 starts on day 5 and has a temperature of 84.0°F.  
 Step 3 starts on day 10 and has a temperature of 82.0°F.

The difference between the step 2 and step 3 set points is 2.0°F:  $(84.0 - 82.0 = 2.0)$ .

There are 5 days in step 2:  $(10 - 5 = 5)$ .

The Heat Mat Control divides the temperature difference by the number of days,  $2.0 \div 5 = 0.4$ , and then automatically adjusts the set point by 0.4°F each day for 5 days.

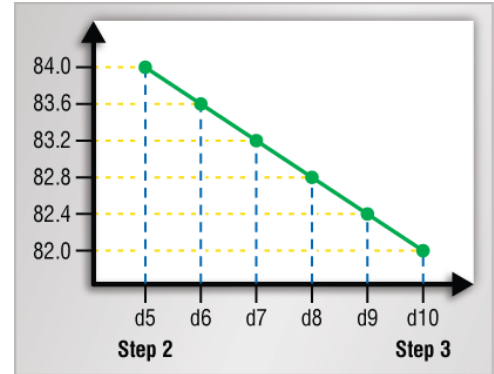
**Enabling and disabling the growth curve**

When the growth curve is not enabled, the current day does not advance and the Heat Mat Control does not automatically adjust the temperature set point.

You can adjust the growth curve steps while the growth curve is not enabled, but you must enable the growth curve before the Heat Mat Control will advance the days and automatically adjust the set point.



When the growth curve is enabled, the **Growth Curve** indicator on the cover is lit.

**To enable or disable the growth curve**

1. In the Program Settings menu, press **Down** until the cursor is beside **Growth Curve**, and then press **Select**.
2. With the cursor beside **Status**, press **Select**.
3. Press **Up** or **Down** to change the setting, and then press **Select**.
4. Press **Down** to continue the next growth curve setting, or press **Back** to return to the Program Settings menu.

```
PROGRAM SETTINGS
 1 Set Point
→2 Growth Curve
 3 Alarms
```

```
GROWTH CURVE
→Status      :Disable
Current Day:001
Restart Day:OFF
```

### Restarting the growth curve at day 1

Restart the growth curve at day 1 by pressing and holding **Up** and **Down** at the same time.

### Changing the current day of the growth curve

When the growth curve is enabled, the Heat Mat Control automatically advances the current day and adjusts the set point each day at midnight. However, there may be times when you want to adjust the day forward or backward. You can do that easily by changing the current day of the curve.

#### To change the current day

1. In the Program Settings menu, press **Down** until the cursor is beside **Growth Curve**, and then press **Select**.
2. Press **Down** until the cursor is beside **Current Day**, and then press **Select**.
3. Press **Up** or **Down** to change the day, and then press **Select**.
4. Press **Down** to continue the next growth curve setting, or press **Back** to return to the Program Settings menu.

```
PROGRAM SETTINGS
 1 Set Point
+2 Growth Curve
 3 Alarms
```

```
GROWTH CURVE
Status      :Enabled
+Current Day:001
Restart Day:OFF
```

### Changing the restart curve day

By default, when the growth curve is finished its last day, the Heat Mat Control maintains the final set point until you restart the curve. Optionally, you can program the control to restart the curve after any number of days, up to 365.

*Default:* OFF

*Range:* 1 to 365

#### To change the current day

1. In the Program Settings menu, press **Down** until the cursor is beside **Growth Curve**, and then press **Select**.
2. Press **Down** until the cursor is beside **Restart Day**, and then press **Select**.
3. Press **Up** or **Down** to change the day, and then press **Select**.
4. Press **Down** to continue the next growth curve setting, or press **Back** to return to the Program Settings menu.

```
PROGRAM SETTINGS
 1 Set Point
+2 Growth Curve
 3 Alarms
```

```
GROWTH CURVE
Status      :Enabled
Current Day:001
+Restart Day:OFF
```

### Programming the growth curve steps

The growth curve can have up to 6 steps. Each step has a start day and a temperature. The maximum length for the growth curve is 365 days.

- ◆ Growth curve temperatures can increase or decrease as the curve progresses.
- ◆ Growth curve of days must increase as the curve progresses.



- ◇ Use the **Appendix B: Factory defaults and worksheet** when programming the growth curve.
- ◇ If you do not want to use all the steps in the growth curve, program the steps you want to use. Program the remaining steps the same as your last one. For example, if you want to use steps 1 to 5, program step 6 the same as 5.

### To program growth curve steps

1. In the Program Settings menu, press **Down** until the cursor is beside **Growth Curve**, and then press **Select**.
2. Press **Up** or **Down** until the cursor is beside the step you want to program, and then press **Select**.
3. Press **Up** or **Down** to change the day, and then press **Select**.
4. Press **Up** or **Down** to change the temperature, and then press **Select**.
5. Repeat steps 2 to 4 for each step you want to program.
6. When finished, press **Back** until you reach the menu you want.

```
PROGRAM SETTINGS
 1 Set Point
→2 Growth Curve
 3 Alarms
```

```
Restart Day:OFF
-----
Step| Day| Temp
→  1|  1| 98.0°F
```

### Programming alarm settings

There are four alarm conditions: high temperature, low temperature, power fail, and probe fail. The alarm settings determine which alarm conditions are enabled and their settings.

When the temperature is above the **high temperature alarm** or below the **low temperature alarm**, there is an alarm condition. If the alarm condition is present for one continuous minute, the control activates the alarm relay and displays the alarm message. The minimum duration prevents alarms from occurring when the temperature rises or drops for just a few seconds.

When the temperature returns to the normal range, the control deactivates the alarm relay. The alarm message remains until you acknowledge it.

**Example**

For example, say the high temperature alarm setting is 105 degrees Fahrenheit. If the temperature rises to 106 degrees, but drops below 105 degrees 30 seconds later, the alarm relay does not activate. If the temperature rises to 106 degrees and stays there for more than 1 minute, the alarm relay activates. The alarm relay remains activated until the temperature drops below the alarm setting.

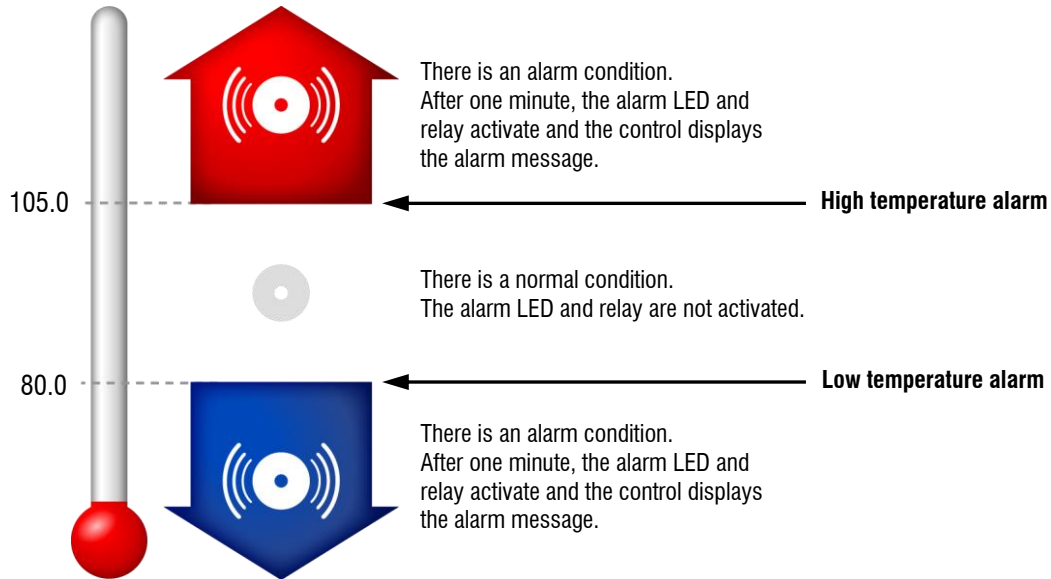

When an alarm occurs, the **Alarm LED** switches on, the alarm message displays, and the alarm relay activates. For more information about acknowledging and responding to alarms, read **Acknowledging alarms** on page 23.

**To program high and low alarm settings**

1. In the Program Settings menu, press **Down** until the cursor is beside **Alarms**, and then press **Select**.
2. Press **Up** or **Down** until the cursor is beside the setting you want to program, and then press **Select**.
3. To adjust a high or low alarm, press **Up** or **Down** to adjust the setting, and then press **Select**.
4. To enable or disable the alarm, press **Up** or **Down** to change the setting, and then press **Select**.
5. Repeat steps 2 to 4 for each step you want to program.
6. When finished, press **Back** once to return to the Program Settings menu, or twice to return to the Main menu.

```
PROGRAM SETTINGS
1 Set Point
2 Growth Curve
+3 Alarms
```

```
+High: 105.0 Enable
Low : 80.0 Enable
Probe Fail: Enable
Power Fail: Enable
```

---

## Chapter 4: Monitoring and maintaining your HMC-2

- ◆ **Monitoring your Heat Mat Control** below
- ◆ **Servicing and maintaining your control** on page 24.

### Monitoring your Heat Mat Control

Your Heat Mat Control displays temperature, mode, alarm, and status information. Monitoring the control regularly gives you a better idea of what is going on with your equipment and in your facility.

#### Mode

The mode is the method of control you are using, set point or growth curve. In both modes, the display shows the set point ( **SP** ). In growth curve mode, the display alternates between showing the set point and the day of the curve.

Normal mode	Growth curve mode
<pre>NURSERY 3      13:21 Mode:Normal SP: 99.0 Temp:100.3°F H:101.4 Output: 30% L: 98.2</pre>	<pre>NURSERY 3      13:21 Mode: Curve Day  4 Temp:100.3°F H:101.4 Output: 30% L: 98.2</pre>

#### Daily high and low temperatures

The daily high ( **H** ) and low ( **L** ) temperatures are shown in the bottom right of the display. The values reset each day at midnight.

#### Acknowledging alarms

The alarm relay activates if an enabled alarm condition is present for longer than the minimum duration of one minute. The one-minute minimum duration prevents alarms from occurring when the temperature rises or drops for just a few seconds. The exception to the 1-minute minimum is the power fail alarm. The power fail alarm automatically triggers the relay on a loss of power.

When an alarm occurs, the alarm relay activates, the LED for **Alarm** switches on, and the alarm message displays. If there is more than one message, after acknowledging the first alarm, the next one displays.

```
LOW TEMP ALARM
-----
Occurred at: 00:13
Temperature: 68.8°F
```

### To acknowledge alarms

Press **Select** two times.

If there was only one alarm message, the Heat Mat Control clears the message and returns to the Main display. If there are additional alarm messages, the next message displays.



For a list of alarm messages, their descriptions, and possible resolutions, read **Alarm and error messages** on page 30.



- ◇ Acknowledging alarms clears the alarm message and deactivates the alarm relay and LED.
- ◇ If you acknowledge the alarm, but do not resolve the problem causing the alarm condition, the alarm occurs again in one minute without any key presses.
- ◇ If the condition causing the alarm returns to normal (for example, the temperature drops below the high alarm setting), the alarm relay and LED deactivate, but the alarm message remains.

## Servicing and maintaining your control

### Using manual override mode

Manual override mode is for individually testing the installation and equipment connected to the Heat Mat Control. When you go into manual override mode, the control sets the output to 0%. You can then change the output from 0 to 100% for the variable stage, and OFF or ON for the alarm relay.

The variable stage and alarm relay remain at the state you set them until you leave manual override. When you leave manual override, the control returns to normal, programmed operation. For example, if you adjust the variable stage to 100%, it stays at 100% until you leave manual override.



- ◇ When the control is in manual override mode, it does not operate the equipment according to the measured temperature.
- ◇ The control *does not* automatically exit manual override mode. When you are finished testing, press **Back** until you return to the Parameter menu.



### To use manual override

1. In the Main menu, with the cursor beside **Manual Override**, press **Select**.
2. Press **Up** or **Down** until the cursor is beside the item you want to override, and then press **Select**.
3. Press **Select** and then press **Up** or **Down** to adjust the output or switch the relay state.  
The output changes as you adjust the value on the screen. The output will stay where you set it until you return to the Main menu or display.
4. If you want to override both the output and alarm relay at the same time, press **Back** until you reach the Manual override menu, and then go to step 2.
5. To exit manual override and return to normal operation, press **Back** until you return to the Main menu or display.

```
MAIN MENU
→1 Manual Override
  2 Program Settings
  3 Configuration
```

```
MANUAL OVERRIDE
→1 Output Level
  2 Alarm Relay
```

```
Output Level:
→ 0%
```

### Saving and restoring settings

The HMC-2 Saver is an innovative and easy-to-use product that allows you to store your Heat Mat Control configuration and settings. The HMC-2 Saver stores a complete copy of all a Heat Mat Control's configuration and settings. You can restore the configuration and settings any time, or even use them to set up new controls in seconds!

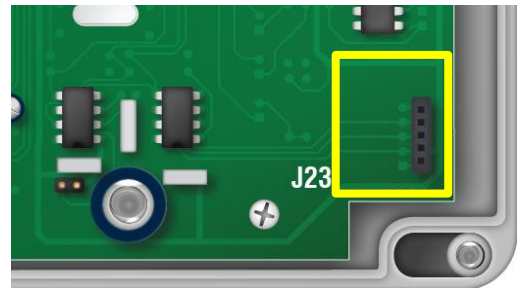

### To save settings

1. Loosen the four screws in the enclosure and then gently remove the cover. Make sure not to disconnect the ribbon cable.
2. Plug the HMC-2 Saver onto the connector labeled **J23** on the inside bottom-right of the cover.
3. In the Configuration menu, press **Down** until the cursor is beside **Save Settings**, and then press **Select** two times.
4. Press **Up** or **Down** to change the **No** to **Yes**, and then press **Select**.  
The control saves the changes to the HMC-2 Saver.
5. After the process completes, press **Back** until you reach the menu or display you want.
6. Remove the HMC-2 Saver.

```
CONFIGURATION
→5 Save Settings
  6 Restore Settings
  7 Factory Defaults
```

```
Save To SAVER?
→Yes
```

```
→Save: Done!
```

- Replace the cover and then tighten the four screws.

### To restore settings

- Loosen the four screws in the enclosure and then gently remove the cover. Make sure not to disconnect the ribbon cable.
- Plug the HMC-2 Saver onto the connector labeled **J23** on the inside bottom-right of the cover.
- At the Configuration menu, scroll to **Restore Settings** and then press **Select** two times.
- Press **Up** or **Down** to change the **No** to **Yes**, and then press **Select**.  
The control restores the settings from the HMC-2 Saver.
- After the process completes, press **Back** until you reach the menu or display you want.
- Remove the HMC-2 Saver.
- Replace the cover and then tighten the four screws.

```
CONFIGURATION
5 Save Settings
→6 Restore Settings
7 Factory Defaults
```

```
Restore From SAUER?
→Yes
```

```
→ Restore: Done!
```

### Displaying the version

Firmware is similar to operating system software for a computer. It contains instructions that tell your Heat Mat Control how to operate.

If you need to contact Customer Support about your Heat Mat Control, you might need to provide them with the firmware version of your control. The firmware version is a number in the format **###**.

### To display the version

- In the Main menu, press **Down** until the cursor is beside **About**, and then press **Select**.
- Press **Back** to return to the main menu.

```
1 Manual Override
2 Program Settings
3 Configuration
→4 About
```

```
Heat Mat Control
Version V#.#
          ##/##/####
```

## Restoring the factory defaults

When your Heat Mat Control leaves the factory, it comes with default settings and configuration. When you program your control, you change the configuration and settings.

Resetting your control erases all the configuration and settings you programmed and restores them to what they were when the control left the factory. For a list of the factory defaults, read **Appendix B: Factory defaults and worksheet** on page 31.



- ◇ **Restore the factory defaults only as a last resort. It erases ALL your configuration and settings and you will have to reconfigure the control.**
- ◇ If you restore your Heat Mat Control to its factory defaults, disconnect the power to all loads and then reconfigure the control before restoring power to the loads.

### To restore the factory defaults

1. In the Configuration menu, press **Down** until the cursor is beside **Factory Defaults**, and then press **Select**.
2. Press **Select**.
3. Press **Up** or **Down** to change the **No** to **Yes**, and then press **Select**.  
The control restores the factory defaults.
4. Press **Back** until you reach the menu or you want.

```
4 Frequency
5 Save Settings
6 Restore Settings
→7 Factory Defaults
```

```
Load Defaults?
→Yes
```

```
→ Reset: Done!
```

## Updating the firmware

The optional HMC-2 Updater allows you to upgrade your Heat Mat Control's firmware as new versions become available. The HMC-2 Updater takes only seconds to use and can upgrade all the Heat Mat Controls at your site.

There are two methods for updating the firmware:

- ◆ **Power on:** the power on method allows you to update the firmware using the menu system, without having to switch the incoming power off and then on. If the power on method fails, use the power off method.
- ◆ **Power off:** the power off method allows you to update the firmware by switching the incoming power off and then on. Use the power off method if the power on method fails.

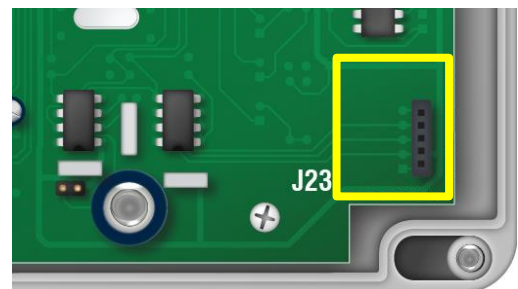

**To update the firmware using the *power on* method**

1. Loosen the four screws in the enclosure and then gently remove the cover. Make sure not to disconnect the ribbon cable.
2. Plug the HMC-2 Updater onto the connector labeled **J23** on the inside bottom-right of the cover.
3. At the Configuration menu, scroll to **Update Firmware** and then press **Select**.
4. Press **Select**.
5. Press **Up** or **Down** to change the **No** to **Yes**, and then press **Select**.  
The control updates the firmware and then restarts.

```
CONFIGURATION
6 Restore Settings
7 Factory Defaults
→8 Update Firmware
```

```
Update Firmware?
→Yes
```

```
Updating...
```



Because the Heat Mat Control resets during the update process, you will see a power fail message displayed. Acknowledge the message and then continue normally. For more information, read **Acknowledging alarms** on page 23.

**To update the firmware using the *power off* method**

1. Loosen the four screws in the enclosure and then gently remove the cover. Make sure not to disconnect the ribbon cable.
2. Plug the HMC-2 Updater onto the connector labeled **J23** on the inside bottom-right of the cover.
3. Switch off the power to the Heat Mat Control for at least five seconds.
4. Switch on the power to the control.  
The control updates its firmware. During the update, the display is blank and the control beeps.  
When the update is complete, the control resets, displays the current version for a couple seconds, and then shows the ambient temperature.
5. Remove the HMC-2 Updater.
6. Verify that the control functions properly.
7. Replace the cover and then tighten the four screws.

## Optional accessories and kits

Replacement kits and optional, convenient accessories are available to enhance and extend your Heat Mat Control. For more information about accessories and kits, contact your dealer.

### Replacement kits

If your Heat Mat Control's bottom circuit board or display fails, you can replace it with a kit.

- ◆ The **control kit** part number is **K310041**.
- ◆ The **display kit** part number is **KHMC2-DISPLAY**.  
After replacing the display, you will need to reprogram control.

### Heat Mat Controller Slave

The Heat Mat Controller Slave (**model HH-HMC-2S**) is an affordable way to increase the load capacity of the Heat Mat Control. The HH-HMC-2S is easy to install and there is no additional configuration required; all slave units follow the settings of the master control.

The Heat Mat Controller Slave comes with a cable that connects to the **SLAVE 1** connection on the Heat Mat Control. You can connect up to 3 Slaves to the HH-HMC-2S. Each Slave increases the current capacity of the stage by 20 amps.



### Features

- ◆ One 20-amp variable stage
- ◆ Expandable capacity using additional slaves
- ◆ Rugged enclosure (corrosion resistant, water resistant, and fire retardant)
- ◆ CSA approval
- ◆ Limited warranty (two years)

## Appendices

- ◆ **Appendix A: Troubleshooting** below
- ◆ **Appendix B: Factory defaults and worksheet** on page 31
- ◆ **Appendix C: Surge suppression and electrical noise** on page 33

### Appendix A: Troubleshooting

- ◆ If you see an alarm or error message and are not sure what it means, look it up in the **Alarm and error messages** table below and then follow the instructions for resolving the condition.
- ◆ If you are having a problem using your Heat Mat Control, see if the problem is described in the **Troubleshooting** table on page 31. Follow the directions for correcting the problem.

#### Alarm and error messages

Message	Possible solution
<p style="text-align: center;">HIGH TEMP ALARM</p> <p>-----</p> <p>Occurred at: 15:37 Temperature: 110.0°F</p>	<ul style="list-style-type: none"> <li>◇ Try to lower the temperature by turning heat mats down or off.</li> <li>◇ Check the temperature probe.</li> <li>◇ Check the alarm settings. For more information, read <b>Programming alarm settings</b> on page 21.</li> </ul>
<p style="text-align: center;">LOW TEMP ALARM</p> <p>-----</p> <p>Occurred at: 00:13 Temperature: 68.8°F</p>	<ul style="list-style-type: none"> <li>◇ Try to raise the temperature by turning heat mats up or on.</li> <li>◇ Check the temperature probe.</li> <li>◇ Check to see if a heat mat has failed.</li> <li>◇ Check the alarm settings. For more information, read <b>Programming alarm settings</b> on page 21.</li> </ul>
<p style="text-align: center;">PROBE FAIL</p> <p>-----</p> <p>Occurred at: 09:42</p>	<ul style="list-style-type: none"> <li>◇ Check the wire between the control and the probe. Any wire damage can cause the alarm.</li> <li>◇ Replace or reconnect the temperature probe. The control should recover automatically.</li> </ul>
<p style="text-align: center;">POWER FAIL</p> <p>-----</p> <p>Occurred at: 19:06</p>	<ul style="list-style-type: none"> <li>◇ Check the circuit breaker panel.</li> <li>◇ If there has not been a power failure, check the ribbon cable connection. For more information, read <b>Heat Mat Control layout</b> on page 9.</li> </ul>
<p style="text-align: center;">ERROR</p> <p>-----</p> <p>No Saver connected</p>	<ul style="list-style-type: none"> <li>◇ Make sure the HMC-2 Saver is inserted correctly and then try again.</li> </ul>

## Troubleshooting

The following table lists some problems that could occur, along with their possible causes and solutions. If you are having a problem with your Heat Mat Control, see if the problem is described in the table and then follow the directions to correct the problem.

Problem	Possible cause	Possible solution
Power supply components blown out  Burn marks on boards and components	Power surge, brownout, or power outage	◇ Avoid the problem in future by providing proper voltage and protection for the control.
No power and/or display	A circuit breaker at service panel is off or tripped. Incorrect incoming power wiring The display board connect cable is not plugged into the control board properly.	◇ Reset the circuit breaker.  ◇ Correct the wiring. ◇ Plug in the display board cable. For more information, read <b>Heat Mat Control layout</b> on page 9.
Display showing unusually high or low temperature	The probe correction value is set too high.  The extension cable connected to the temperature probe is providing a poor connection Damaged probe	◇ Adjust the value. For more information, read <b>Setting the probe correction value</b> on page 16.  ◇ Check the extension cable connection and re-solder it if necessary.  ◇ Replace the temperature probe.

## Appendix B: Factory defaults and worksheet

When your Heat Mat Control leaves the factory, it comes with default settings and configuration. Configuring and programming the control changes the factory defaults. Restoring factory defaults erases all the configuration and settings you programmed and restores the defaults. For more information, read **Restoring the factory defaults** on page 27.

Parameter	Default	Range/options	Your setting/notes
<b>Program settings</b>			
Set point	99.0	70 to 125°F (21.1 to 51.7°C)	
Growth curve enable	NO	YES or NO	
Current day	1	1 to 365	
Restart curve day	OFF	0 to 365	
Step 1 day	1	0 to 365	
Step 1 temperature	98.0	70 to 125°F (21.1 to 51.7°C)	
Step 2 day	9	Step 1 day to 365	
Step 2 temperature	93.0	70 to 125°F (21.1 to 51.7°C)	
Step 3 day	17	Step 2 day to 365	
Step 3 temperature	88.0	70 to 125°F (21.1 to 51.7°C)	
Step 4 day	17	Step 3 day to 365	
Step 4 temperature	88.0	70 to 125°F (21.1 to 51.7°C)	
Step 5 day	17	Step 4 day to 365	
Step 5 temperature	88.0	70 to 125°F (21.1 to 51.7°C)	
Step 6 day	17	Step 5 day to 365	
Step 6 temperature	88.0	70 to 125°F (21.1 to 51.7°C)	
High temperature alarm	105.0 / Enabled	70 to 125°F (21.1 to 51.7°C)	
Low temperature alarm	80.0 / Enabled	70 to 125°F (21.1 to 51.7°C)	
Probe damage enable	Enabled	Enabled / Disabled	
Power fail enable	Enabled	Enabled / Disabled	
<b>Configuration</b>			
Room name	NAME	Up to 12 characters	
Probe type	Type B 1K	A (3K), B (1K), or C (5K)	
Probe correction	-6.0	-9.0 to 9.0°F (-5.0 to 5.0°C)	
Temperature units	°F	°F or °C	
Time (24 hour)	---	00:00 to 23:59	
Frequency	60	50 or 60 Hz	



## **Appendix C: Surge suppression and electrical noise**

### **Understanding power surges and surge suppression**

Power surges can be caused by external influences (for example, lightning or utility distribution problems) or they can be caused internally (for example, starting and stopping inductive loads such as motors).

One of the most common causes of power surges is lightning. When lightning strikes the ground, it produces an enormously powerful electromagnetic field. This field affects nearby power lines, which transmit a surge to any device connected to it, such as lights, computers, or environmental controls like your Heat Mat Control. Lightning does not have to strike a power line to transmit a surge.

Surge suppression devices offer some protection from power surges. Because it is not possible to internally protect this product completely from the effects of power surges and other transients, Innovative Heating Technologies highly recommend that you install external surge suppression devices. For specific recommendations, see your electrical contractor. If you do not take these precautions, you acknowledge your willingness to accept the risk of loss or injury.

### **Reducing electrical noise using filters**

Electrical noise is caused by high voltage transients created when inductive loads, such as power contactors, are switched on or off. The strength of the transients can be over 1000 volts and can vary with the type of equipment and wiring, as well as several other factors.

*Visible* symptoms of electrical noise include erratic control operation, cycling inlets, communication problems, and more. However, the effects of electrical noise are *not always visible*. Over time, electrical noise can cause electronic circuits, relay contacts, and power contactors to deteriorate.

---

## ***Index***

### **A**

- acknowledging alarms ..... 23–24
- alarm codes ..... 30
- alarm relay ..... 9
- alarm settings . 18–22, *See also*, acknowledging alarms
- alarm system ..... 12

### **B**

- buttons..... 6

### **C**

- Celsius ..... *See* temperature units
- clock ..... 17
- configuring..... *See also*, programming
  - operating frequency ..... 17
  - probe correction value ..... 16
  - temperature units ..... 16
- cover ..... 6
- current day..... 20
- curve ..... *See* growth curve

### **D**

- defaults ..... *See* factory defaults
- degrees..... *See* temperature units
- disabling growth curve ..... 19
- display ..... 6
- display cable..... 9

### **E**

- electrical noise..... 33
- electrical ratings ..... 5
- enabling growth curve..... 19
- error codes ..... 30

### **F**

- factory defaults ..... 27, 31–32
- Fahrenheit..... *See* temperature units

- features..... 5
- filters ..... 33
- firmware version ..... 27–28
- frequency ..... 17
- fuse..... 9, *See also*, electrical ratings

### **G**

- growth curve..... 18–21

### **H**

- heat settings..... 18
- high temperature alarm..... 18–22
- HMB Saver ..... 25–27
- HMB Updater..... 27–28

### **I**

- incoming power..... 9
- inside view ..... 9
- installing
  - alarm system..... 12

### **K**

- kits ..... 29

### **L**

- layout..... 9
- LEDs ..... 6
- low temperature alarm ..... 18–22

### **M**

- manual override ..... 24–25
- messages ..... 30
- minimum heat..... 18
- mounting ..... 8

### **N**

- normally open/closed..... *See* alarm system

**O**

- operating frequency ..... 17
- operating the control ..... 6–7

**P**

- parameters..... *See specific parameter*
- power..... 9
- probe correction value ..... 16
- programming ..... *See also, configuring*
  - alarm settings..... 18–22
  - growth curve ..... 18–21
  - heat settings..... 18
  - set point..... 18

**R**

- ratings ..... 5
- repair kits ..... 29
- responding to alarms ..... 23–24, *See also, troubleshooting*
- restoring factory defaults..... 27
- restoring settings..... 25–27
- ribbon cable..... 9

**S**

- saving settings ..... 25–27
- set point..... 18
- setting..... *See configuring, See programming*
- Single-Phase Slave ..... 29
- slave units..... 9, *See also Single-Phase Slave*
- status LEDs ..... 6

**T**

- temperature probe ..... 9
- temperature units ..... 16
- terminals..... 9
- time..... 17
- troubleshooting ..... 30–31

**U**

- units..... *See temperature units*
- updating firmware ..... 27–28

**V**

- variable terminals ..... 9
- version..... *See firmware version*



## Limited warranty

This warranty applies only to the Hog Hearth Heat Mat Controller (HH-HMC-2). If you need warranty service, return the product and original proof of purchase to your dealer.

Phason Inc. (Phason) warrants the HH-HMC-2 subject to the following terms and conditions.

This warranty is valid only to the original purchaser of the product, for two years from the manufacturing date. The manufacturing date is stated in the first eight digits of the serial number in the form year-month-day.

Phason hereby warrants that should the HH-HMC-2 fail because of improper workmanship, Phason will repair the unit, effecting all necessary parts replacements without charge for either parts or labor.

### Conditions

- ◆ Installation must be done according to our enclosed installation instructions.
- ◆ The product must not have been previously altered, modified, or repaired by anyone other than Phason.
- ◆ The product must not have been involved in an accident, misused, abused, or operated or installed contrary to the instructions in our user and/or installation manuals. Phason's opinion about these items is final.
- ◆ The person requesting warranty service must be the original purchaser of the unit, and provide proof of purchase upon request.
- ◆ All transportation charges for products submitted for warranty must be paid by the purchaser.

Except to the extent prohibited by applicable law, no other warranties, whether expressed or implied, including warranties of merchantability and fitness for a particular purpose, shall apply to the HH-HMC-2. Any implied warranties are excluded.

Phason is not liable for consequential damages caused by the HH-HMC-2.

Phason does not assume or authorize any representatives, or other people, to assume any obligations or liabilities, other than those specifically stated in this warranty.

Phason reserves the right to improve or alter the HH-HMC-2 without notice.

## Service and technical support

Innovative Heating will be happy to answer all technical questions that will help you use your **Individual Mat Control**. Before contacting us, check the following:

- ◆ Read this manual for information about the feature with which you are having trouble.
- ◆ If you see an alarm message and are not sure what it means, look it up in the **Alarm and error messages** table on page 30 and then follow the instructions for resolving the alarm condition.
- ◆ If you are having a problem using your Individual Mat Control, look in **Appendix A: Troubleshooting** on page 30, and then follow the directions for correcting the problem.
- ◆ If you still have a problem with your Individual Mat Control, collect the following information:
  - ◆ The serial number
  - ◆ Any messages displayed
  - ◆ A description of the problem
  - ◆ A description of what you were doing before the problem occurred



- ◇ Innovative Heating controls are designed and manufactured to provide reliable performance, but they are not guaranteed to be 100 percent free of defects. Even reliable products can experience occasional failures and the user should recognize this possibility.
- ◇ If Innovative Heating products are used in a life-support ventilation system where failure could result in loss or injury, the user should provide adequate back up ventilation, supplementary natural ventilation, or an independent failure-alarm system. The user's lack of such precautions acknowledges their willingness to accept the risk of such loss or injury.

Innovative Heating  
205 Oakland Road  
Oak Bluff, Manitoba, Canada  
R4G 0A4

Phone: 204-896-7500  
Toll free: 800-728-9661  
Fax: 204-885-0903

E-mail: [hoghearth@ihtech.ca](mailto:hoghearth@ihtech.ca)  
Web: [innovativeheatingtech.com](http://innovativeheatingtech.com)

## Button names and functions



### Down

Press to move down or decrease a value.



### Up

Press to move up or increase a value.



### Back

Press to go back to the previous item or screen.  
Press and hold to switch the control on/off.



### Select

Press to select an option or accept a value.

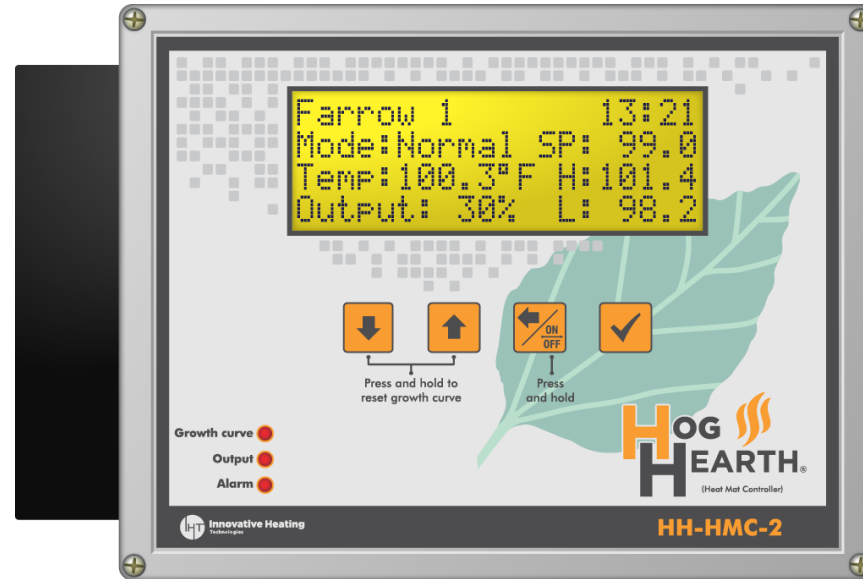

## Configure these items for initial setup

- ◇ Room name
- ◇ Temperature probe
  - Type
  - Units
  - Correction
- ◇ Time
- ◇ Frequency

## Program and adjust these items for heat mat operation

- ◇ Set point
- ◇ Growth curve
  - Enabled or disabled
  - Current day
  - Restart day
  - Up to 6 steps (start day and temperature)
- ◇ Alarms
  - High temperature
  - Low temperature
  - Probe fail
  - Power fail

## Main display and menus

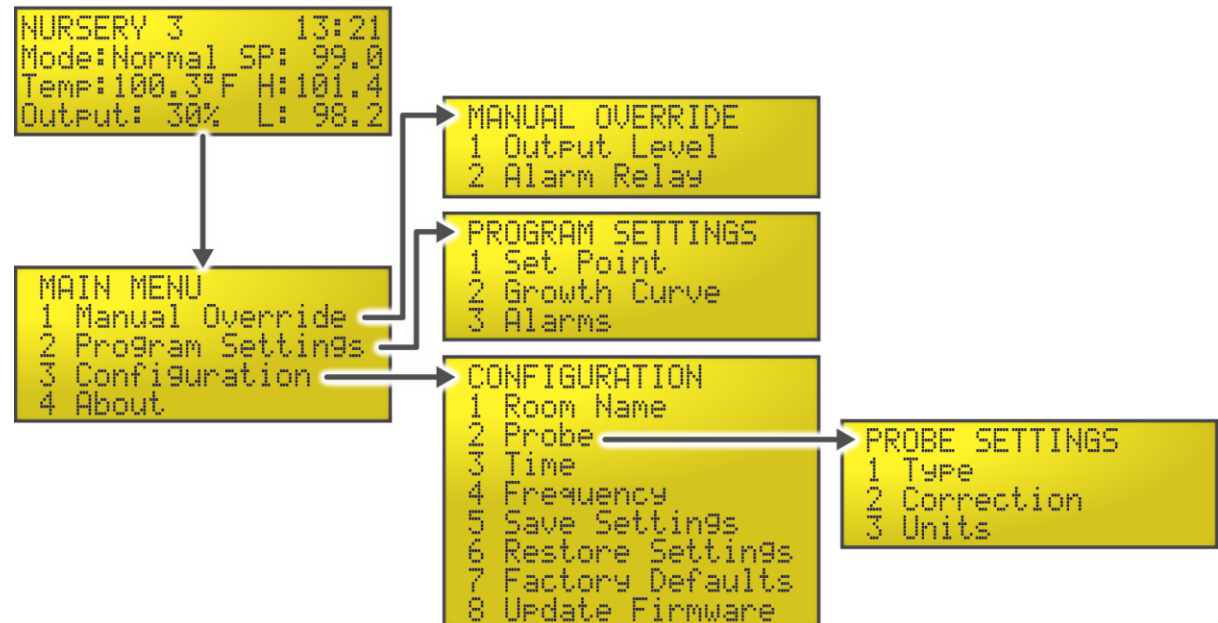

# Installation

## Power and heat mat connections

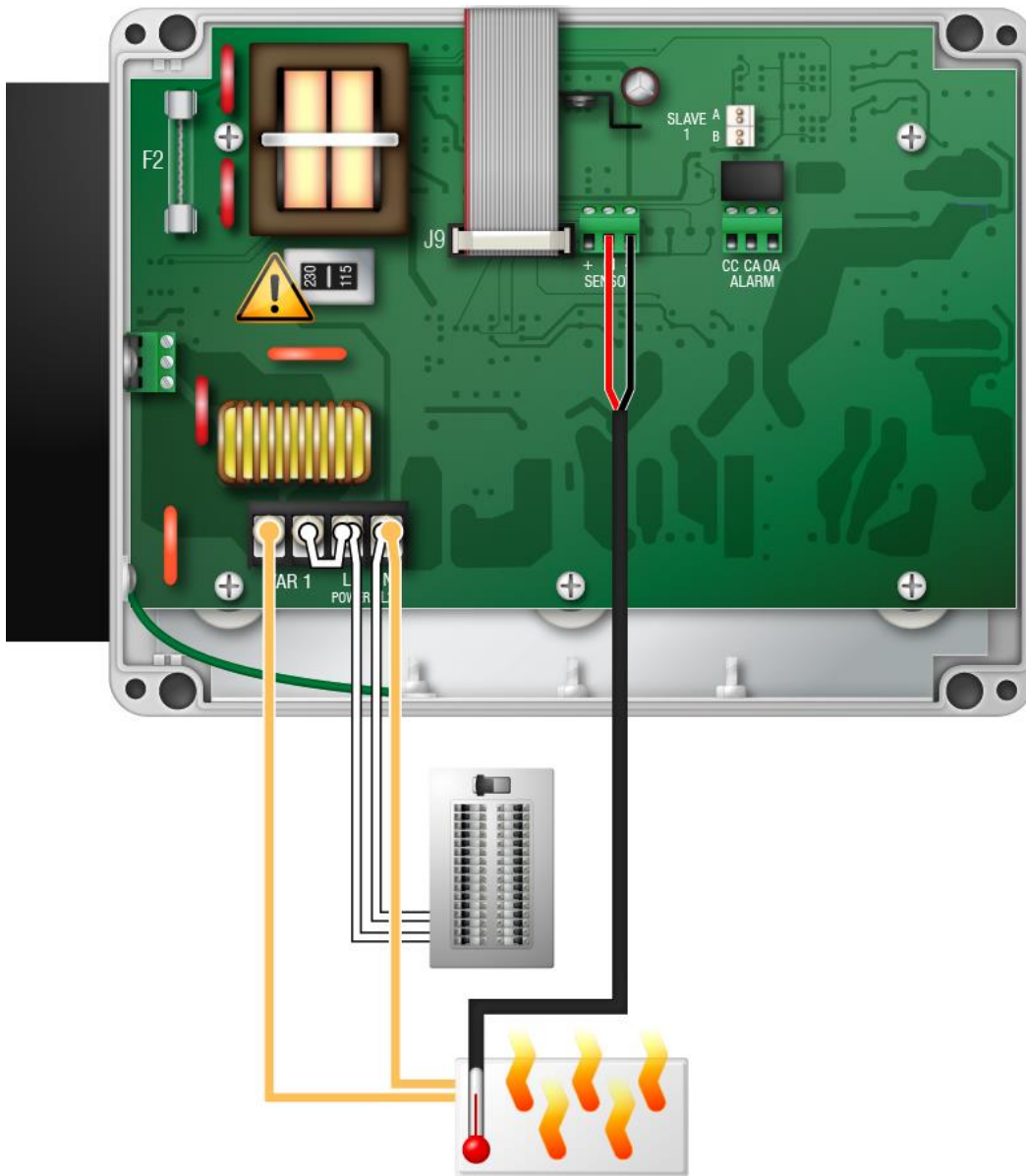

## Electrical ratings

- ◇ **Input power:**  
120/230 VAC, 50/60 Hz
- ◇ **Input fuse:**  
250 V, 1 A fast-acting glass
- ◇ **Variable AC:**  
20 A at 120/230 VAC, general-purpose resistive  
2300 W at 120 VAC; 4600 W at 230 VAC
- ◇ **Alarm relay:**  
0.4 A at 125 VAC; 2 A at 30 VDC, resistive load  
0.2 A at 125 VAC; 1 A at 30 VDC, inductive load

## Alarm connections

### Normally OPEN system (closed on alarm)

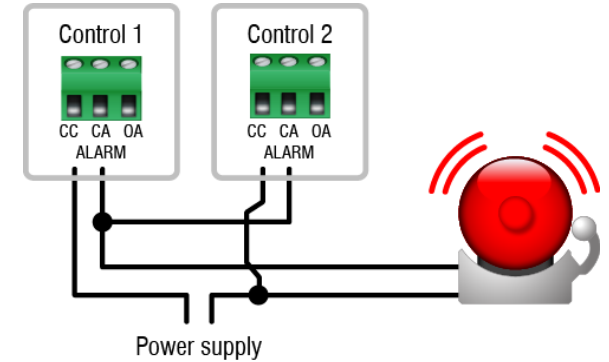

### Normally CLOSED system (open on alarm)

